

ABB ABILITY™ SMART SUBSTATION CONTROL AND PROTECTION FOR ELECTRICAL SYSTEMS
MARCH 2020

PRODUCT GUIDE

SSC600



Contents

1. Description	3	16. Interconnection functions.....	27
2. Protection functions.....	3	17. Power quality functions.....	28
3. Supported ABB Solutions.....	4	18. Control functions	29
4. Control	5	19. Condition monitoring and supervision functions	30
5. Measurements.....	5	20. Measurement functions	30
6. Power quality.....	5	21. Other functions.....	31
7. Disturbance recorder	6	22. WHMI	32
8. Event log	6	23. Selection and ordering data	32
9. Recorded data	6	24. Tools.....	32
10. Condition monitoring	7	25. Cyber security	34
11. Self-supervision	7	26. References	34
12. Access control.....	7	27. Functions, codes and symbols	34
13. Station communication.....	7	28. Order form.....	37
14. Technical data	9	29. Application Packages	39
15. Protection functions.....	11		

Disclaimer

The information in this document is subject to change without notice and should not be construed as a commitment by ABB. ABB assumes no responsibility for any errors that may appear in this document.

© Copyright 2020 ABB.

All rights reserved.

Trademarks

ABB and Relion are registered trademarks of the ABB Group. All other brand or product names mentioned in this document may be trademarks or registered trademarks of their respective holders.

SSC600

Product version: 1.1

1. Description

ABB Ability™ Smart Substation Control and Protection for electrical systems SSC600 is a smart substation device designed for protection, control, measurement and supervision of utility substations and industrial switchgear and equipment. The design of the device has been guided by the IEC 61850 standard for communication and interoperability of substation automation devices. It is fully integrable with Relion series IEDs for creating a complete solution. Optional functionality is available at the time of order for both software and hardware, for example, special application packages and additional communication modules.



Figure 1. SSC600

Re-engineered from the ground up, the SSC series has been designed to unleash the full potential of the IEC 61850 standard for communication and interoperability between substation automation devices.

The device provides main protection for overhead lines and cable feeders in distribution networks. The device is also used as backup protection in applications, where an independent and redundant protection system is required.

Depending on the chosen product options, the device is adapted for:

- Protection for overhead line and cable feeder in isolated neutral, resistance earthed, compensated and solidly earthed networks.
- Protection, control, measurement and supervision of asynchronous motors in manufacturing and process industry.
- Transformer protection and control for power transformers, unit and step-up transformers including power generator-transformer blocks in utility and industry power distribution systems.

Once the device has been given the application-specific settings, it can directly be put into service.

2. Protection functions

The device offers directional and non-directional overcurrent and thermal overload protection as well as directional and nondirectional earth-fault protection. Some product options allow as an option admittance-based, harmonics-based or wattmetric-based earth-fault protection to be used in addition to directional earth-fault protection. Further, the device features sensitive earth-fault protection, phase discontinuity protection, transient/intermittent earth-fault protection, distance protection, overvoltage and undervoltage protection, residual overvoltage protection, positive-sequence undervoltage and negative-sequence overvoltage protection. Frequency protection, including overfrequency, underfrequency and frequency rate-of-change protection, is offered in devices with some product options. The device also incorporates optional three-pole multishot autoreclosing functions for overhead line feeders.

The device features three-phase, multi-slope stabilized (biased) stage transformer differential protection and an instantaneous stage to provide fast and selective protection for phase-to-phase short circuit, winding interturn fault and bushing flashover protection. Besides second harmonic restraint, an advanced waveform-based blocking algorithm ensures stability at transformer energization and a fifth harmonic restraint function ensures good protection stability at moderate overexcitation of power transformers.

Sensitive restricted earth-fault protection completes the overall differential protection providing detection of even single phase-to-

earth faults close to the neutral earthing point of the transformer. Either the conventional high-impedance scheme or a numerical low-impedance scheme can be selected for protection of the transformer windings. When low-impedance restricted earth-fault protection is used neither stabilizing resistors nor varistors are needed and as a further benefit the transforming ratio of the neutral earthing CTs can differ from those of the phase current transformers. Due to its unit protection character and absolute selectivity restricted earth fault does not need to be timegraded with other protection schemes, and therefore high speed fault clearance can be achieved. The device also incorporates a thermal overload protection function, which supervises the thermal stress of the transformer windings to prevent premature aging of the insulation of the windings. Multiple stages of short circuit, phase overcurrent, negative-sequence and earth-fault backup protection are separately available for both sides of the power transformer. Earth-fault protection based on the measured or calculated residual voltage is also available. Further, the device also offers circuit breaker failure protection.

The device offers all the functionality needed to manage motor start-ups and normal operation, also including protection and fault clearance in abnormal situations. The main features of the device include thermal overload protection, motor start-up supervision, locked rotor protection and protection against too frequent motor start-ups. The device also incorporates nondirectional earth-fault protection, negative phase-sequence current unbalance protection and backup overcurrent protection. Furthermore, the device offers motor running stall protection, loss-of-load supervision and phase reversal protection. In certain motor drives of special importance there must be a possibility to override the motor thermal overload protection to perform an emergency start of a hot motor. To enable an emergency hot start, the SSC600 offers a forced start execution feature.

Some product options additionally offer multifrequency admittance-based earth-fault protection providing selective directional earth-fault protection for high-impedance earthed networks. The operation is based on multifrequency neutral admittance measurement utilizing fundamental frequency and harmonic components in U_0 and I_0 . A special filtering algorithm enables dependable and secure fault direction also during intermittent/restriking earth faults. It provides a very good combination of reliability and sensitivity of protection with a single function for low ohmic and higher ohmic earth faults and for transient and intermittent or restriking earth faults.

SSC600 also features optional arc fault protection of the circuit breaker, busbar and cable compartment of metal-enclosed indoor switchgear. Light detection needs to be included in the bay level devices.

3. Supported ABB Solutions

The SSC600 Smart Substation devices together with the Substation Management Unit COM600S constitute a genuine IEC 61850 solution for reliable power distribution in utility and industrial power systems. To facilitate the system engineering, ABB's devices are supplied with connectivity packages. The connectivity packages include a compilation of software and device-specific information, including single-line diagram templates and a full device data model. The data model includes event and parameter lists. With the connectivity packages, the devices can be readily configured using PCM600 and integrated with COM600S or the network control and management system MicroSCADA Pro.

The SSC600 Smart Substation devices offer native support for IEC 61850 Edition 2 also including binary and analog horizontal GOOSE messaging. In addition, with process bus the receiving of sampled values of voltages is supported. Compared to traditional hardwired, inter-device signaling, peer-to-peer communication over a switched Ethernet LAN offers an advanced and versatile platform for power system protection. Among the distinctive features of the protection system approach, enabled by the full implementation of the IEC 61850 substation automation standard, are fast communication capability, continuous supervision of the protection and communication system's integrity, and an inherent flexibility regarding reconfiguration and upgrades. This protection device series is able to optimally utilize interoperability provided by the IEC 61850 Edition 2 features.

At substation level, COM600S uses the data content of the devices to enhance substation level functionality. COM600S features a Web browser-based HMI, which provides a customizable graphical display for visualizing single-line mimic diagrams for switchgear bay solutions. Substation devices and processes can also be remotely accessed through the Web HMI, which improves personnel safety.

In addition, COM600S can be used as a local data warehouse for the substation's technical documentation and for the network data collected by the devices. The collected network data facilitates extensive reporting and analyzing of network fault situations by using the data historian and event handling features of COM600S. The historical data can be used for accurate monitoring of process and equipment performance, using calculations based on both real-time and historical values. A better understanding of the process dynamics is achieved by combining time-based process measurements with production and maintenance events.

COM600S can also function as a gateway and provide seamless connectivity between the substation devices and network-level control and management systems, such as MicroSCADA Pro and System 800xA. In addition COM600S can combine redundant SSC600 units so network-level systems see only a single solution.

GOOSE Analyzer interface in COM600S enables the following and analyzing the horizontal IEC 61850 application during commissioning and operation at station level. It logs all GOOSE events during substation operation to enable improved system supervision.

4. Control

SSC600 integrates functionality for the control of a circuit breaker via the Web HMI or by means of remote controls. In addition to the circuit-breaker control the device features control blocks which are intended for motor-operated control of disconnectors or circuit breaker truck and for their position indications. Further, the device offers control block that is intended for motor-operated control of earthing switch control and its position indication.

Two physical binary inputs and two physical binary outputs are needed in the bay level merging unit or in the IED (not in SSC) for each controllable primary device taken into use.

If the amount of available binary inputs or outputs of the chosen merging unit or IED is not sufficient, an external input or output module, for example, RIO600 can be integrated to the IED. The binary inputs and outputs of the external I/O module can be used for the less time critical binary signals of the application.

SSC600 includes WHMI and a single-line diagram (SLD) with position indication for the relevant primary devices. Interlocking schemes required by the application are configured using the signal matrix or the application configuration functionality of PCM600. Depending on the product options, the device also incorporates a synchrocheck function to ensure that the voltage, phase angle and frequency on either side of an open circuit breaker satisfy the conditions for safe interconnection of two networks.

5. Measurements

Based on received 9-2 streams, SSC600 continuously measures

- The phase currents
- The symmetrical components of the currents
- The residual current and residual voltage, based on the received process bus measurements
- The residual voltage
- The phase voltages
- The voltage sequence components
- Frequency

The device also calculates the demand value of the current over a user-selectable, pre-set time frame, the thermal overload of the protected object, and the phase unbalance based on the ratio between the negative-sequence and positive-sequence current.

Furthermore, the device offers three-phase power and energy measurement including power factor.

The measured values can be accessed remotely via the communication interface of the device. The values can also be accessed locally or remotely using the Web HMI.

6. Power quality

In the EN standards, power quality is defined through the characteristics of the supply voltage. Transients, short-duration and long-duration voltage variations and unbalance and waveform distortions are the key characteristics describing power quality. The distortion monitoring functions are used for monitoring the current total demand distortion and the voltage total harmonic distortion.

Power quality monitoring is an essential service that utilities can provide for their industrial and key customers. A monitoring system can provide information about system disturbances and their possible causes. It can also detect problem conditions throughout the system before they cause customer complaints, equipment malfunctions and even equipment damage or failure. Power quality problems are not limited to the utility side of the system. In fact, the majority of power quality problems are localized within customer facilities. Thus, power quality monitoring is not only an effective customer service strategy but also a way to protect a utility's reputation for quality power and service.

The protection relay has the following power quality monitoring functions.

- Voltage variation
- Voltage unbalance
- Current harmonics
- Voltage harmonics

The voltage unbalance and voltage variation functions are used for measuring shortduration voltage variations and monitoring voltage unbalance conditions in power transmission and distribution networks.

The voltage and current harmonics functions provide a method for monitoring the power quality by means of the current waveform distortion and voltage waveform distortion. The functions provides a short-term three-second average and a long-term demand for total demand distortion TDD and total harmonic distortion THD.

7. Disturbance recorder

The device is provided with a disturbance recorder featuring up to 160 analog channels and 512 binary channels. The analog channels can be set to record either the waveform or the trend of the currents and voltages measured.

The binary signal channels can be set to start a recording either on the rising or the falling edge of the binary signal or on both. By default, the binary channels are set to record external or internal device signals, for example, the start or trip signals of the device stages, or external blocking or control signals. Binary device signals, such as protection start and trip signals, or an external device control signal via a binary input, can be set to trigger the recording. Recorded information is stored in a non-volatile memory and can be uploaded for subsequent fault analysis.

8. Event log

To collect sequence-of-events information, the device has a nonvolatile memory capable of storing 8192 events with the associated time stamps. The non-volatile memory retains its data even if the device temporarily loses its auxiliary supply. The event log facilitates detailed pre- and post-fault analyses of feeder faults and disturbances. The considerable capacity to process and store data and events in the device facilitates meeting the growing information demand of future network configurations. The sequence-of-events information can be accessed remotely via the communication interface of the device. The information can also be accessed locally or remotely using the Web HMI.

9. Recorded data

The device has the capacity to store the records of the 128 latest fault events. The records can be used to analyze the power system events. Each record includes, for example, current, voltage and angle values and a time stamp. The fault recording can be triggered by the start or the trip signal of a protection block, or by both. The available measurement modes include DFT, RMS and peak-to-peak. Fault records store device measurement values at the moment when any protection function starts. In addition, the maximum demand current with time stamp is separately recorded. The records are stored in the non-volatile memory.

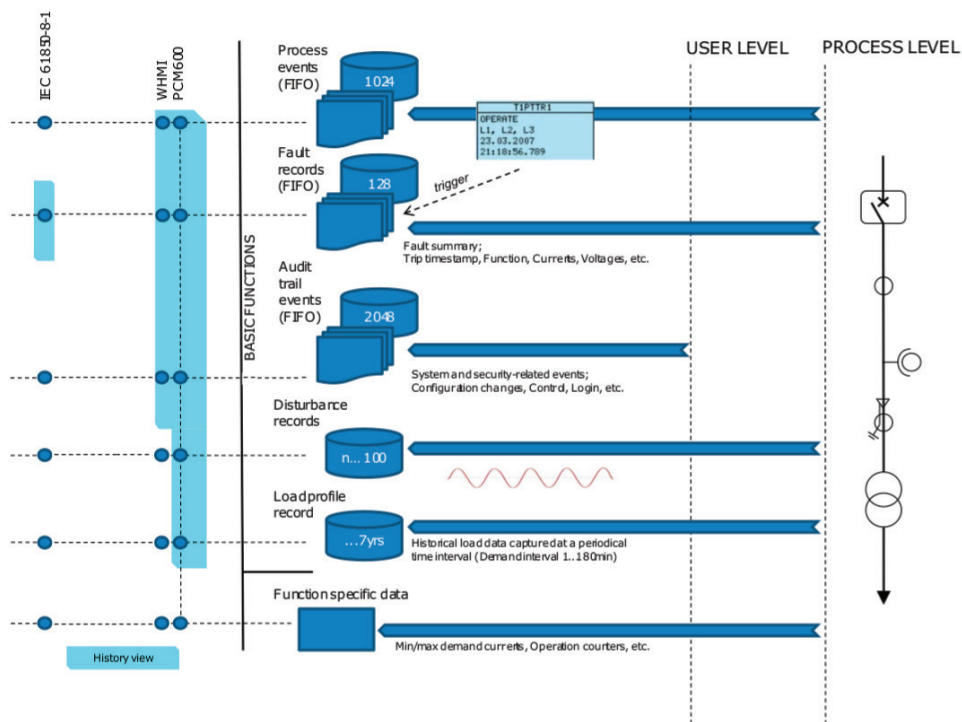

Figure 2. Recording and event capabilities overview

10. Condition monitoring

The condition monitoring functions of the device constantly monitor the performance and the condition of the circuit breaker. The monitoring comprises the spring charging time, SF6 gas pressure, the travel time and the inactivity time of the circuit breaker.

The monitoring functions provide operational circuit breaker history data, which can be used for scheduling preventive circuit breaker maintenance.

In addition, the device includes a runtime counter for monitoring of how many hours a protected device has been in operation thus enabling scheduling of time-based preventive maintenance of the device.

11. Self-supervision

The devices built-in self-supervision system continuously monitors the state of the device hardware and the operation of the device software. Any fault or malfunction detected is used for alerting the operator.

A permanent device fault blocks the protection functions to prevent incorrect operation.

12. Access control

To protect the device from unauthorized access and to maintain information integrity, the device is provided with a four-level, rolebased authentication system with programmable individual passwords for the viewer, operator, engineer and administrator levels. The access control applies to the Web HMI and PCM600.

13. Station communication

The device supports a range of communication protocols including IEC 61850 Edition 1, Edition 2 and IEC 61850-9-2 LE. Operational information and controls are available through these protocols.

The IEC 61850 protocol is a core part of the device as the protection and control application is fully based on standard modelling. The device supports Edition 2 and Edition 1 versions of the standard. With Edition 2 support, the device has the latest functionality modelling for substation applications and the best interoperability for modern substations. It incorporates also the full support of standard device mode functionality supporting different test applications. Control applications can utilize the new safe and advanced station control authority feature.

The IEC 61850 communication implementation supports monitoring and control functions. Additionally, parameter settings, disturbance recordings and fault records can be accessed using the IEC 61850 protocol. Disturbance recordings are available to

any Ethernet-based application in the standard COMTRADE file format. The device supports simultaneous event reporting to five different clients on the station bus. The device can exchange data with other devices using the IEC 61850 protocol.

The device can send binary and analog signals to other devices using the IEC 61850-8-1 GOOSE (Generic Object Oriented Substation Event) profile. Binary GOOSE messaging can, for example, be employed for protection and interlocking-based protection schemes. The device meets the GOOSE performance requirements for tripping applications in distribution substations, as defined by the IEC 61850 edition 2 standard (<3 ms point-to-point data exchange between the devices). The device also supports the sending and receiving of analog values using GOOSE messaging. Analog GOOSE messaging enables easy transfer of analog measurement values over the station bus, thus facilitating for example the sending of measurement values between the devices when controlling parallel running transformers.

The device also supports IEC 61850 process bus by receiving sampled values of voltages and currents. With this functionality the galvanic interpanel wiring can be replaced with Ethernet communication. The measured values are received as sampled values using IEC 61850-9-2 LE protocol. SSC600 devices with process bus based applications use IEEE 1588 for high accuracy time synchronization.

For redundant Ethernet communication, the device offers either two optical or two galvanic Ethernet network interfaces, depending on the product variant. Ethernet network redundancy can be achieved using the parallel redundancy protocol (PRP). In addition to the process communication, SSC600 also has dedicated Ethernet interfaces for local WHMI and engineering.

The IEC 61850 standard specifies network redundancy which improves the system availability for the substation communication. The network redundancy is based on protocols defined in the IEC 62439-3 standard: PRP protocol. The protocol is able to overcome a failure of a link or switch with a zero switch-over time. In the protocol, each network node has two identical Ethernet ports dedicated for one network connection. The protocol relies on the duplication of all transmitted information and provide a zero switchover time if the links or switches fail, thus fulfilling all the stringent real-time requirements of substation automation.

In PRP, each network node is attached to two independent networks operated in parallel. The networks are completely separated to ensure failure independence and can have different topologies. The networks operate in parallel, thus providing zero-time recovery and continuous checking of redundancy to avoid failures.

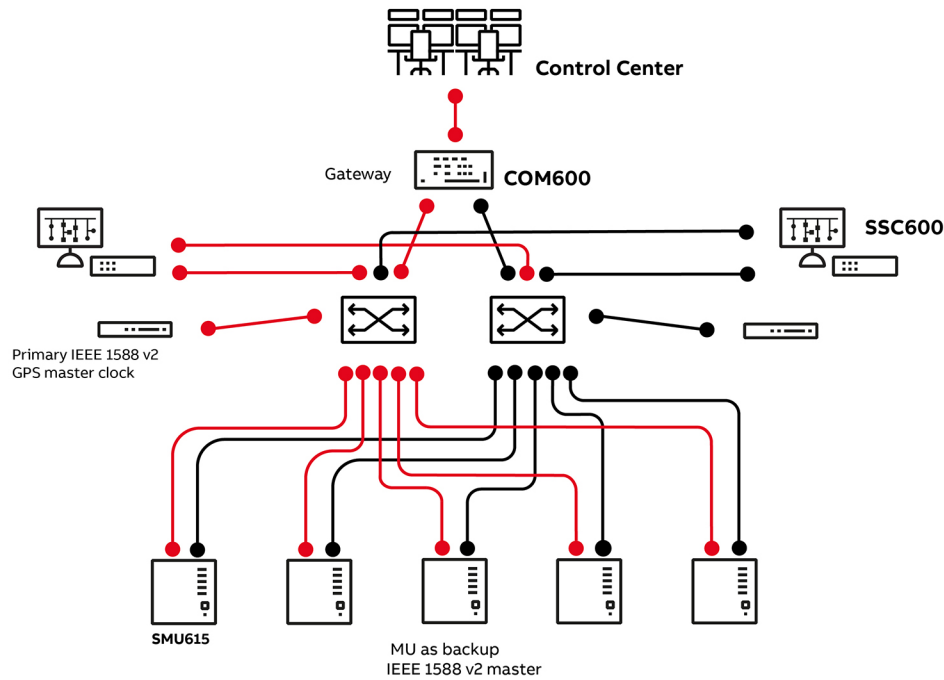

Figure 3. Parallel redundancy protocol (PRP) solution

The device can be connected to Ethernet-based communication systems via the RJ-45 connector (100Base-TX) or the fiber optic LC connector (1000Base-SX), depending on the product variant.

The device supports the following high accuracy time synchronization method with a timestamping resolution of 4 μ s required especially in process bus applications.

- PTP (IEEE 1588) v2 with Power Profile

IEEE 1588 v2 features

- Ordinary Clock with Best Master Clock algorithm
- One-step Transparent Clock for Ethernet ring topology
- 1588 v2 Power Profile
- Receive (slave): 1-step/2-step
- Transmit (master): 1-step
- Layer 2 mapping
- Peer to peer delay calculation
- Multicast operation

Required accuracy of grandmaster clock is $\pm 1 \mu$ s.

14. Technical data

Table 1. Dimensions

Description	Value
Width	440 mm / 17.3"
Height	88 mm / 3.4"
Depth	220 mm / 8.6"
Weight	6.0kg
Mounting	2U Rack mount (19"), fits into standard 19" rack

Table 2. Power supply

Description	High Voltage variant	Low Voltage variant
Nominal auxiliary voltage Un	100...240 VAC 50 and 60Hz 100...240 VDC	36...72 VDC
Maximum interruption time in the auxiliary DC voltage without resetting the device	50 ms at Un	
Auxiliary voltage variation	85...110% of Un (85...264VAC) 80...117% of Un (80...280 VDC)	
Start-up threshold		
Power consumption	35 W (Typical)	35 W (Typical)
Ripple in the DC auxiliary voltage	Max 10% of the DC value (at frequency of 100 Hz)	
Fuse type		

Table 3. Ethernet interfaces

Ethernet interface	Protocol	Cable	Data transfer rate
All	TCP/IP protocol	Standard Ethernet CAT 5 cable with RJ-45 connector	1000 Mbits/s

Table 4. Environmental conditions

Description	Value
Operating temperature range	-20...+55°C (continuous)
Short-time service temperature range	-25...+70°C (<16h) ^{1,2}
Relative humidity	<95%, non-condensing
Atmospheric pressure	
Altitude	
Transport and storage temperature range	-30...+85°C

Table 5. Electromagnetic Compatibility (EMC)

Description	IEC 61850-3 Reference	Requirement	Test standard	Test ports
Electrostatic discharge	6.7.3	6 kV contact 8 kV air	IEC 6100-4-2	E
Radiated, radiofrequency electromagnetic field 80 MHz - 3000 MHz	6.7.3	AM 80% 1kHz, 10 V/m	IEC 6100-4-3	E
Fast transient/burst	6.7.3	4 kV	IEC 6100-4-4	A,B,D
Surge	6.7.3	line to ground 4,0 kV line to line 2,0 kV	IEC 6100-4-5	A,B
Induced by radio frequency fields	6.7.3	AM 80% 1kHz, 10 V	IEC 6100-4-6	A,B,D
Power frequency magnetic field	6.7.3	100 A/m continuous 1000 A/m 1s	IEC 6100-4-8	E
Voltage dips Voltage interruptions	6.7.3	ΔU 30% for 1 period ΔU 60% for 50 period ΔU 100% for 5 period ΔU 100% for 50 period	IEC 6100-4-11	A

¹ Degradation in MTBF and HMI performance outside the temperature range of -25...+55 °C

² For devices with an LC communication interface the maximum operating temperature is +70 °C

SSC600

Product version: 1.1

Description	IEC 61850-3 Reference	Requirement	Test standard	Test ports
Mains frequency voltage	6.7.3	30 V cont. 300 V 1s	IEC 6100-4-16	A,B
Ripple on d.c. power supply	6.7.3	10% of Un	IEC 6100-4-17	A
Damped oscillatory wave	6.7.3	2,5 kV CM 1,0 kV DM	IEC 6100-4-18	A,B
Conducted emission	6.7.3	Class A	CISPR 22	A
Radiated emission	6.7.3	Class A	CISPR 22	E

Port:
A Mains power supply input
B Ethernet port
D Functional earth port
H House

Table 6. Insulation tests

Test Description	IEEE 1613-2009	Requirement	Test Standard
Dielectric test	5.2	2kV, 0.5kV	IEEE 1613-2009 5.2
Impulse test	5.3	5kV	IEEE 1613-2009 5.3

Table 7. Mechanical environmental condition

Test Description	IEC 61850-3 reference	Requirement	Test Standard
Vibration response and endurance test	6.10.1	Class 1	IEC 60255-21-1
Shock response test	6.10.2	Class 1	IEC 60255-21-2
Shock endurance test	6.10.2	Class 1	IEC 60255-21-2
Bump test	6.10.2	Class 1	IEC 60255-21-2
Dry heat test - Operational	6.9.3.1	70 °C	IEC 60068-2-2 Test Bd
Cold test - Operational	6.9.3.2	-20 °C	IEC 60068-2-1 Test Ad
Dry heat test - Maximum storage temperature	6.9.3.3	85 °C	IEC 60068-2-2 Test Bb
Cold test - Minimum storage temperature	6.9.3.4	-30 °C	IEC 60068-2-1 Test Ad
Change of temperature test	6.9.3.5	70 °C and -20 °C	IEC 60068-2-14 Test Nb
Damp heat steady state test	6.9.3.6	93% humidity, 40 °C during 10 days	IEC 60068-2-78 Test Cab

Table 8. Product safety

Description	Reference
LV directive	2014/35/EU
Standard	EN 60255-1 (2010) EN 60255-27 (2017)

Table 9. EMC compliance

Description	Reference
EMC directive	2014/30/EU
Standard	EN 60255-26 (2013)

Table 10. RoHS compliance

Description
Complies with RoHS directive 2011/65/EU

Table 11. Certification

Description
CE, FCC, CCC, Electricity IV level for China, IEC-61850-3, IEEE-1613, UL, CB, LVD

15. Protection functions

Table 12. Three-phase non-directional overcurrent protection (PHxPTOC)

Characteristic	Value			
Operation accuracy	PHLPTOC	Depending on the frequency of the measured current: f_n ± 2 Hz		
		$\pm 1.5\%$ of the set value or $\pm 0.002 \times I_n$		
Start time ^{3,4}	PHHPTOC and PHIPTOC	$\pm 1.5\%$ of set value or $\pm 0.002 \times I_n$ (at currents in the range of $0.1 \dots 10 \times I_n$) $\pm 5.0\%$ of the set value (at currents in the range of $10 \dots 40 \times I_n$)		
	PHIPTOC: IFault = $2 \times$ set Start value IFault = $10 \times$ set Start value	Minimum 16 ms 11 ms	Typical 19 ms 12 ms	Maximum 23 ms 14 ms
	PHHPTOC and PHLPTOC: IFault = $2 \times$ set Start value	23 ms	26 ms	29 ms
Reset time	Typically 40 ms			
Reset ratio	Typically 0.96			
Retardation time	<30 ms			
Operate time accuracy in definite time mode	$\pm 1.0\%$ of the set value or ± 20 ms			
Operate time accuracy in inverse time mode	$\pm 5.0\%$ of the theoretical value or ± 20 ms ⁵			
Suppression of harmonics	RMS: No suppression DFT: -50 dB at $f = n \times f_n$, where $n = 2, 3, 4, 5, \dots$ Peak-to-Peak: No suppression P-to-P+backup: No suppression			

Table 13. Three-phase non-directional overcurrent protection (PHxPTOC) main settings

Parameter	Function	Value (Range)	Step
Start value	PHLPTOC	$0.05 \dots 5.00 \times I_n$	0.01
	PHHPTOC	$0.10 \dots 40.00 \times I_n$	0.01
	PHIPTOC	$1.00 \dots 40.00 \times I_n$	0.01
Time multiplier	PHLPTOC and PHHPTOC	$0.05 \dots 15.00$	0.01
Operate delay time	PHLPTOC and PHHPTOC	$40 \dots 200000$ ms	10
	PHIPTOC	$40 \dots 200000$ ms	10
Operating curve type ⁶	PHLPTOC	Definite or inverse time Curve type: 1, 2, 3, 4, 5, 6, 7, 8, 9, 10, 11, 12, 13, 14, 15, 17, 18, 19	
	PHHPTOC	Definite or inverse time Curve type: 1, 3, 5, 9, 10, 12, 15, 17	
	PHIPTOC	Definite time	

Table 14. Three-phase directional overcurrent protection (DPHxPDO)

Characteristic	Value			
Operation accuracy	EFLPTOC	Depending on the frequency of the measured current: f_n ± 2 Hz		
		$\pm 1.5\%$ of the set value or $\pm 0.002 \times I_n$		
Start time ^{7,8}	EFHPTOC and EFIPTOC	$\pm 1.5\%$ of set value or $\pm 0.002 \times I_n$ (at currents in the range of $0.1 \dots 10 \times I_n$) $\pm 5.0\%$ of the set value (at currents in the range of $10 \dots 40 \times I_n$)		
	EFIPTOC: IFault = $2 \times$ set Start value IFault = $10 \times$ set Start value	Minimum 16 ms 11 ms	Typical 19 ms 12 ms	Maximum 23 ms 14 ms
	EFHPTOC and EFLPTOC: IFault = $2 \times$ set Start value	23 ms	26 ms	29 ms
Reset time	Typically 40 ms			

3 Set Operate delay time = 0,02 s, Operate curve type = IEC definite time, Measurement mode = default (depends on stage), current before fault = $0.0 \times I_n$, $f_n = 50$ Hz, fault current in one phase with nominal frequency injected from random phase angle, results based on statistical distribution of 1000 measurements

4 Includes the delay of the signal output contact

5 Includes the delay of the heavy-duty output contact

6 For further reference, see the Operation characteristics table

7 Measurement mode = default (depends on stage), current before fault = $0.0 \times I_n$, $f_n = 50$ Hz, earth-fault current with nominal frequency injected from random phase angle, results based on statistical distribution of 1000 measurements

8 Includes the delay of the signal output contact

SSC600

Product version: 1.1

Characteristic	Value
Reset ratio	Typically 0.96
Retardation time	<30 ms
Operate time accuracy in definite time mode	$\pm 1.0\%$ of the set value or ± 20 ms
Operate time accuracy in inverse time mode	$\pm 1.0\%$ of the set value or ± 20 ms ⁹
Suppression of harmonics	RMS: No suppression DFT: -50 dB at $f = n \times f_n$, where $n = 2, 3, 4, 5, \dots$ Peak-to-Peak: No suppression

Table 15. Three-phase directional overcurrent protection (DPHxPDOC) main settings

Parameter	Function	Value (Range)	Step
Start value	DPHLPDOC	0.05...5.00 $\times I_n$	0.01
	DPHHPDOC	0.10...40.00 $\times I_n$	0.01
Time multiplier	DPHxPDOC	0.05...15.00	0.01
Operate delay time	DPHxPDOC	40...200000 ms	10
Directional mode	DPHxPDOC	1 = Non-directional	-
		2 = Forward	
		3 = Reverse	
Characteristic angle	DPHxPDOC	-179...180°	1
Operating curve type ¹⁰	DPHLPDOC	Definite or inverse time	
		Curve type: 1, 2, 3, 4, 5, 6, 7, 8, 9, 10, 11, 12, 13, 14, 15, 17, 18, 19	
	DPHHPDOC	Definite or inverse time	
		Curve type: 1, 3, 5, 9, 10, 12, 15, 17	

Table 16. Non-directional earth-fault protection (EFxPTOC) main settings

Characteristic	Value			
Operation accuracy	EFLPTOC	Depending on the frequency of the measured current: f_n ± 2 Hz $\pm 1.5\%$ of the set value or $\pm 0.002 \times I_n$		
	EFHPTOC and EFIPTOC	$\pm 1.5\%$ of set value or $\pm 0.002 \times I_n$ (at currents in the range of $0.1 \dots 10 \times I_n$) $\pm 5.0\%$ of the set value (at currents in the range of $10 \dots 40 \times I_n$)		
Start time ^{11, 12}	EFIPTOC:	Minimum	Typical	Maximum
	IFault = 2 \times set Start value	16 ms	19 ms	23 ms
	IFault = 10 \times set Start value	11 ms	12 ms	14 ms
	EFHPTOC and EFLPTOC: IFault = 2 \times set Start value	23 ms	26 ms	29 ms
Reset time	Typically 40 ms			
Reset ratio	Typically 0.96			
Retardation time	<30 ms			
Operate time accuracy in definite time mode	$\pm 1.0\%$ of the set value or ± 20 ms			
Operate time accuracy in inverse time mode	$\pm 1.0\%$ of the set value or ± 20 ms ¹³			
Suppression of harmonics	RMS: No suppression DFT: -50 dB at $f = n \times f_n$, where $n = 2, 3, 4, 5, \dots$ Peak-to-Peak: No suppression			

Table 17. Non-directional earth-fault protection (EFxPTOC) main settings

Parameter	Function	Value (Range)	Step
Start value	EFLPTOC	0.010...5.000 $\times I_n$	0.005
	EFHPTOC	0.10...40.00 $\times I_n$	0.01
	EFIPTOC	1.00...40.00 $\times I_n$	0.01
Time multiplier	EFLPTOC and EFHPTOC	0.05...15.00	0.01
Operate delay time	EFLPTOC and EFHPTOC	40...200000 ms	10
	EFIPTOC	20...200000 ms	10

⁹ Maximum Start value = $2.5 \times I_n$, Start value multiples in range of 1.5...20

¹⁰ For further reference, see the Operating characteristics table

¹¹ Measurement mode = default (depends on stage), current before fault = $0.0 \times I_n$, $f_n = 50$ Hz, earth-fault current with nominal frequency injected from random phase angle, results based on statistical distribution of 1000 measurements

¹² Includes the delay of the signal output contact

¹³ Maximum Start value = $2.5 \times I_n$, Start value multiples in range of 1.5...20

SSC600

Product version: 1.1

Parameter	Function	Value (Range)	Step
Operating curve type ¹⁴	EFLPTOC	Definite or inverse time Curve type: 1, 2, 3, 4, 5, 6, 7, 8, 9, 10, 11, 12, 13, 14, 15, 17, 18, 19	
	EFHPTOC	Definite or inverse time Curve type: 1, 3, 5, 9, 10, 12, 15, 17	
	EFIPTOC	Definite time	

Table 18. Directional earth-fault protection (DEFxPDEF)

Characteristic	Value			
Operation accuracy	EFLPTOC	Depending on the frequency of the measured current: $f_n \pm 2$ Hz $\pm 1.5\%$ of the set value or $\pm 0.002 \times I_n$		
	EFHPTOC and EFIPTOC	$\pm 1.5\%$ of set value or $\pm 0.002 \times I_n$ (at currents in the range of $0.1 \dots 10 \times I_n$) $\pm 5.0\%$ of the set value (at currents in the range of $10 \dots 40 \times I_n$)		
Start time ^{15, 16}	EFIPTOC: $I_{\text{Fault}} = 2 \times \text{set Start value}$ $I_{\text{Fault}} = 10 \times \text{set Start value}$	Minimum	Typical	Maximum
		16 ms 11 ms	19 ms 12 ms	23 ms 14 ms
	EFHPTOC and EFLPTOC: $I_{\text{Fault}} = 2 \times \text{set Start value}$	23 ms	26 ms	29 ms
Reset time	Typically 40 ms			
Reset ratio	Typically 0.96			
Retardation time	<30 ms			
Operate time accuracy in definite time mode	$\pm 1.0\%$ of the set value or ± 20 ms			
Operate time accuracy in inverse time mode	$\pm 1.0\%$ of the set value or ± 20 ms ¹⁷			
Suppression of harmonics	RMS: No suppression DFT: -50 dB at $f = n \times f_n$, where $n = 2, 3, 4, 5, \dots$ Peak-to-Peak: No suppression			

Table 19. Directional earth-fault protection (DEFxPDEF) main settings

Parameter	Function	Value (Range)	Step
Start value	DEFLPDEF	$0.010 \dots 5.000 \times I_n$	0.005
	DEFHPDEF	$0.10 \dots 40.00 \times I_n$	0.01
Directional mode	DEFLPDEF and DEFHPDEF	1 = Non-directional 2 = Forward 3 = Reverse	-
Time multiplier	DEFLPDEF	0.05...15.00	0.01
	DEFHPDEF	0.05...15.00	0.01
Operate delay time	DEFLPDEF	50...200000 ms	10
	DEFHPDEF	40...200000 ms	10
Operating curve type ¹⁸	DEFLPDEF	Definite or inverse time Curve type: 1, 2, 3, 4, 5, 6, 7, 8, 9, 10, 11, 12, 13, 14, 15, 17, 18, 19	
	DEFHPDEF	Definite or inverse time Curve type: 1, 3, 5, 15, 17	
Operation mode	DEFxPDEF	1 = Phase angle 2 = $I_0 \sin$ 3 = $I_0 \cos$ 4 = Phase angle 80 5 = Phase angle 88	-

Table 20. Admittance-based earth-fault protection (EFPADM)

Characteristic	Value		
Operation accuracy ¹⁹	At the frequency $f = f_n$ $\pm 1.0\%$ or ± 0.01 mS (In range of 0.5...100 mS)		
Start time ²⁰	Minimum	Typical	Maximum
	56 ms	60 ms	64 ms
	Reset time	40 ms	

¹⁴ For further reference, see the Operation characteristics table

¹⁵ Measurement mode = default (depends on stage), current before fault = $0.0 \times I_n$, $f_n = 50$ Hz, earth-fault current with nominal frequency injected from random phase angle, results based on statistical distribution of 1000 measurements

¹⁶ Includes the delay of the signal output contact

¹⁷ Maximum Start value = $2.5 \times I_n$, Start value multiples in range of 1.5...20

¹⁸ For further reference, see the Operating characteristics table

¹⁹ $U_0 = 1.0 \times U_n$

²⁰ Includes the delay of the signal output contact, results based on statistical distribution of 1000 measurements Feeder Protection and Control 1MRS756379 S REF615 Product version: 5.0 FP1 52

Characteristic	Value
Operate time accuracy	$\pm 1.0\%$ of the set value of ± 20 ms
Suppression of harmonics	-50 dB at $f = n \times f_n$, where $n = 2, 3, 4, 5, \dots$

Table 21. Admittance-based earth-fault protection (EFPADM) main settings

Parameter	Function	Value (Range)	Step
Voltage start value	EFPADM	$0.01 \dots 2.00 \times U_n$	0.01
Directional mode	EFPADM	1 = Non-directional 2 = Forward 3 = Reverse	-
Operation mode	EFPADM	1 = Yo 2 = Go 3 = Bo 4 = Yo, Go 5 = Yo, Bo 6 = Go, Bo 7 = Yo, Go, Bo	-
Operate delay time	EFPADM	60...200000 ms	10
Circle radius	EFPADM	0.05...500.00 mS	0.01
Circle conductance	EFPADM	-500.00...500.00 mS	0.01
Circle susceptance	EFPADM	-500.00...500.00 mS	0.01
Conductance forward	EFPADM	-500.00...500.00 mS	0.01
Conductance reverse	EFPADM	-500.00...500.00 mS	0.01
Susceptance forward	EFPADM	-500.00...500.00 mS	0.01
Susceptance reverse	EFPADM	-500.00...500.00 mS	0.01
Conductance tilt Ang	EFPADM	-30...30°	1
Susceptance tilt Ang	EFPADM	-30...30°	1

Table 22. Wattmetric-based earth-fault protection (WPWDE)

Characteristic	Value
Operation accuracy	Current and voltage: $\pm 1.5\%$ of the set value or $\pm 0.002 \times I_n$ Power: $\pm 3\%$ of the set value or $\pm 0.002 \times P_n$
Start time 2526	Typically 63 ms
Reset time	Typically 40 ms
Reset ratio	Typically 0.96
Operate time accuracy in definite time mode	$\pm 1.0\%$ of the set value or ± 20 ms
Operate time accuracy in IDMT mode	$\pm 5.0\%$ of the set value or ± 20 ms
Suppression of harmonics	-50 dB at $f = n \times f_n$, where $n = 2, 3, 4, 5, \dots$

Table 23. Wattmetric-based earth-fault protection (WPWDE) main settings

Parameter	Function	Value (Range)	Step
Directional mode	WPWDE	2 = Forward 3 = Reverse	-
Current start value	WPWDE	$0.010 \dots 5.000 \times I_n$	0.001
Voltage start value	WPWDE	$0.010 \dots 1.000 \times U_n$	0.001
Power start value	WPWDE	$0.003 \dots 1.000 \times P_n$	0.001
Reference power	WPWDE	$0.050 \dots 1.000 \times P_n$	0.001
Characteristic angle	WPWDE	-179...180°	1
Time multiplier	WPWDE	0.05...2.00	0.01
Operating curve type ²¹	WPWDE	Definite or inverse time Curve type: 5, 15, 20	
Operate delay time	WPWDE	60...200000 ms	10
Min operate current	WPWDE	$0.010 \dots 1.000 \times I_n$	0.001
Min operate voltage	WPWDE	$0.01 \dots 1.00 \times U_n$	0.01

21 For further reference, refer to the Operating characteristics table

SSC600

Product version: 1.1

Table 24. Transient/intermittent earth-fault protection (INTRPTEF)

Characteristic	Value
Operation accuracy (U _o criteria with transient protection)	Depending on the frequency of the measured current: $f_n \pm 2$ Hz $\pm 1.5\%$ of the set value or $\pm 0.002 \times U_o$
Operate time accuracy	$\pm 1.0\%$ of the set value or ± 20 ms
Suppression of harmonics	DFT: -50 dB at $f = n \times f_n$, where $n = 2, 3, 4, 5$

Table 25. Transient/intermittent earth-fault protection (INTRPTEF) main settings

Parameter	Function	Value (Range)	Step
Directional mode	INTRPTEF	1 = Non-directional 2 = Forward 3 = Reverse	-
Operate delay time	INTRPTEF	40...1200000 ms	10
Voltage start value	INTRPTEF	0.05...0.50 $\times U_n$	0.01
Operation mode	INTRPTEF	1 = Intermittent EF 2 = Transient EF	-
Peak counter limit	INTRPTEF	2...20	1
Min operate current	INTRPTEF	0.01...1.00 $\times I_n$	0.01

Table 26. Negative-sequence overcurrent protection (NSPTOC)

Characteristic	Value												
Operation accuracy	Depending on the frequency of the measured current: f_n $\pm 1.5\%$ of the set value or $\pm 0.002 \times I_n$												
Start time ^{22, 23}	<table border="1"> <thead> <tr> <th></th> <th>Minimum</th> <th>Typical</th> <th>Maximum</th> </tr> </thead> <tbody> <tr> <td>I_{Fault} = 2 \times set Start value</td> <td>24 ms</td> <td>27 ms</td> <td>29 ms</td> </tr> <tr> <td>I_{Fault} = 10 \times set Start value</td> <td>15 ms</td> <td>18 ms</td> <td>20 ms</td> </tr> </tbody> </table>		Minimum	Typical	Maximum	I _{Fault} = 2 \times set Start value	24 ms	27 ms	29 ms	I _{Fault} = 10 \times set Start value	15 ms	18 ms	20 ms
	Minimum	Typical	Maximum										
I _{Fault} = 2 \times set Start value	24 ms	27 ms	29 ms										
I _{Fault} = 10 \times set Start value	15 ms	18 ms	20 ms										
Reset time	Typically 40 ms												
Reset ratio	Typically 0.96												
Retardation time	<35 ms												
Operate time accuracy in definite time mode	$\pm 1.0\%$ of the set value or ± 20 ms												
Operate time accuracy in inverse time mode	$\pm 5.0\%$ of the theoretical value or ± 20 ms ²⁴												
Suppression of harmonics	DFT: -50 dB at $f = n \times f_n$, where $n = 2, 3, 4, 5, \dots$												

Table 27. Negative-sequence overcurrent protection (NSPTOC) main settings

Parameter	Function	Value (Range)	Step
Start value	NSPTOC	0.01...5.00 $\times I_n$	0.01
Time multiplier	NSPTOC	0.05...15.00	0.01
Operate delay time	NSPTOC	40...200000 ms	10
Operating curve type ²⁵	NSPTOC	Definite or inverse time Curve type: 1, 2, 3, 4, 5, 6, 7, 8, 9, 10, 11, 12, 13, 14, 15, 17, 18, 19	

Table 28. Phase discontinuity protection (PDNSPTOC)

Characteristic	Value
Operation accuracy	Depending on the frequency of the measured current: $f_n \pm 2$ Hz
Start time	<70 ms
Reset time	Typically 40 ms
Reset ratio	Typically 0.96
Retardation time	<35 ms
Operate time accuracy in definite time mode	$\pm 1.0\%$ of the set value or ± 20 ms
Suppression of harmonics	DFT: -50 dB at $f = n \times f_n$, where $n = 2, 3, 4, 5, \dots$

22 Negative sequence current before fault = 0.0, $f_n = 50$ Hz, results based on statistical distribution of 1000 measurements

23 Includes the delay of the signal output contact

24 Maximum Start value = 2.5 $\times I_n$, Start value multiples in range of 1.5...20

25 For further reference, see the Operation characteristics table

Table 29. Phase discontinuity protection (PDNSPTOC) main settings

Parameter	Function	Value (Range)	Step
Start value	PDNSPTOC	10...100%	1
Operate delay time	PDNSPTOC	100...300000 ms	1
Min phase current	PDNSPTOC	0.05...0.30 × I _n	0.01

Table 30. Table 33: Residual overvoltage protection (ROVPTOV)

Characteristic	Value
Operation accuracy	Depending on the frequency of the measured voltage: f _n ±2 Hz ±1.5% of the set value or ±0.002 × U _n
Start time ^{26, 27}	U _{Fault} = 2 × set Start value Minimum 48 ms Typical 51 ms Maximum 54 ms
Reset time	Typically 40 ms
Reset ratio	Typically 0.96
Retardation time	<35 ms
Operate time accuracy in definite time mode	±1.0% of the set value or ±20 ms
Suppression of harmonics	DFT: -50 dB at f = n × f _n , where n = 2, 3, 4, 5,...

Table 31. Residual overvoltage protection (ROVPTOV) main settings

Parameter	Function	Value (Range)	Step
Start value	ROVPTOV	0.010...1.000 × U _n	0.001
Operate delay time	ROVPTOV	40...300000 ms	1

Table 32. Three-phase undervoltage protection (PHPTUV)

Characteristic	Value
Operation accuracy	Depending on the frequency of the measured voltage: f _n ±2 Hz ±1.5% of the set value or ±0.002 × U _n
Start time ^{28, 29, 30}	U _{Fault} = 0.9 × set Start value Minimum 62 ms Typical 66 ms Maximum 70 ms
Reset time	Typically 40 ms
Reset ratio	Depends on the set Relative hysteresis
Retardation time	<35 ms
Operate time accuracy in definite time mode	±1.0% of the set value or ±20 ms
Operate time accuracy in inverse time mode	±5.0% of the theoretical value or ±20 ms ³¹
Suppression of harmonics	DFT: -50 dB at f = n × f _n , where n = 2, 3, 4, 5,...

Table 33. Three-phase undervoltage protection (PHPTUV) main settings

Parameter	Function	Value (Range)	Step
Start value	PHPTUV	0.05...1.20 × U _n	0.01
Time multiplier	PHPTUV	0.05...15.00	0.01
Operate delay time	PHPTUV	60...300000 ms	10
Operating curve type ³²	PHPTUV	Definite or inverse time Curve type: 5, 15, 21, 22, 23	

26 Residual voltage before fault = 0.0 × U_n, f_n = 50 Hz, residual voltage with nominal frequency injected from random phase angle, results based on statistical distribution of 1000 measurements

27 Includes the delay of the signal output contact

28 Start value = 1.0 × U_n, Voltage before fault = 1.1 × U_n, f_n = 50 Hz, undervoltage in one phase-to-phase with nominal frequency injected from random phase angle, results based on statistical distribution of 1000 measurements

29 Includes the delay of the signal output contact

30 Minimum Start value = 0.50, Start value multiples in range of 0.90...0.20

31 Minimum Start value = 0.50, Start value multiples in range of 0.90...0.20

32 For further reference, see the Operation characteristics table

SSC600

Product version: 1.1

Table 34. Three-phase overvoltage protection (PHPTOV)

Characteristic	Value		
Operation accuracy	Depending on the frequency of the measured voltage: $f_n \pm 2$ Hz $\pm 1.5\%$ of the set value or $\pm 0.002 \times U_n$		
Start time ^{33, 34}	UFault = 1.1 × set Start value	Minimum	Typical
		23 ms	27 ms
			Maximum
			31 ms
Reset time	Typically 40 ms		
Reset ratio	Depends on the set Relative hysteresis		
Retardation time	<35 ms		
Operate time accuracy in definite time mode	$\pm 1.0\%$ of the set value or ± 20 ms		
Operate time accuracy in inverse time mode	$\pm 5.0\%$ of the theoretical value or ± 20 ms ³⁵		
Suppression of harmonics	DFT: -50 dB at $f = n \times f_n$, where $n = 2, 3, 4, 5, \dots$		

Table 35. Three-phase overvoltage protection (PHPTOV) main settings

Parameter	Function	Value (Range)	Step
Start value	PHPTOV	0.05...1.60 × U_n	0.01
Time multiplier	PHPTOV	0.05...15.00	0.01
Operate delay time	PHPTOV	40...300000 ms	10
Operating curve type ⁴²	PHPTOV	Definite or inverse time Curve type: 5, 15, 17, 18, 19, 20	

Table 36. Positive-sequence undervoltage protection (PSPTUV)

Characteristic	Value		
Operation accuracy	Depending on the frequency of the measured voltage: $f_n \pm 2$ Hz $\pm 1.5\%$ of the set value or $\pm 0.002 \times U_n$		
Start time ^{36, 37}	UFault = 0.99 × set Start value UFault = 0.9 × set Start value	Minimum	Typical
		52 ms 44 ms	55 ms 47 ms
			Maximum
			58 ms 50 ms
Reset time	Typically 40 ms		
Reset ratio	Depends on the set Relative hysteresis		
Retardation time	<35 ms		
Operate time accuracy in definite time mode	$\pm 1.0\%$ of the set value or ± 20 ms		
Suppression of harmonics	DFT: -50 dB at $f = n \times f_n$, where $n = 2, 3, 4, 5, \dots$		

Table 37. Positive-sequence undervoltage protection (PSPTUV) main settings

Parameter	Function	Value (Range)	Step
Start value	PSPTUV	0.010...1.200 × U_n	0.001
Operate delay time	PSPTUV	40...120000 ms	10
Voltage block value	PSPTUV	0.01...1.00 × U_n	0.01

Table 38. Negative-sequence overvoltage protection (NSPTOV)

Characteristic	Value		
Operation accuracy	Depending on the frequency of the measured voltage: $f_n \pm 2$ Hz $\pm 1.5\%$ of the set value or $\pm 0.002 \times U_n$		
Start time ^{38, 39}	UFault = 1.1 × set Start value UFault = 2.0 × set Start value	Minimum	Typical
		33 ms 24 ms	35 ms 26 ms
			Maximum
			37 ms 28 ms

33 Start value = $1.0 \times U_n$, Voltage before fault = $0.9 \times U_n$, $f_n = 50$ Hz, overvoltage in one phase-to-phase with nominal frequency injected from random phase angle, results based on statistical distribution of 1000 measurements

34 Includes the delay of the signal output contact

35 Maximum Start value = $1.20 \times U_n$, Start value multiples in range of 1.10...2.00

36 Start value = $1.0 \times U_n$, positive-sequence voltage before fault = $1.1 \times U_n$, $f_n = 50$ Hz, positive sequence undervoltage with nominal frequency injected from random phase angle, results based on statistical distribution of 1000 measurements

37 Includes the delay of the signal output contact

38 Negative-sequence voltage before fault = $0.0 \times U_n$, $f_n = 50$ Hz, negative-sequence overvoltage with nominal frequency injected from random phase angle, results based on statistical distribution of 1000 measurements

39 Includes the delay of the signal output contact

SSC600

Product version: 1.1

Characteristic	Value
Reset time	Typically 40 ms
Reset ratio	Typically 0.96
Retardation time	<35 ms
Operate time accuracy in definite time mode	$\pm 1.0\%$ of the set value or ± 20 ms
Suppression of harmonics	DFT: -50 dB at $f = n \times f_n$, where $n = 2, 3, 4, 5, \dots$

Table 39. Negative-sequence overvoltage protection (NSPTOV) main settings

Parameter	Function	Value (Range)	Step
Start value	NSPTOV	0.010...1.000 $\times U_n$	0.001
Operate delay time	NSPTOV	40...120000 ms	1

Table 40. Frequency protection (FRPFRQ)

Characteristic	Value
Operation accuracy	$f > / f <$ df/dt ± 5 mHz ± 50 mHz/s (in range $ df/dt < 5$ Hz/s) $\pm 2.0\%$ of the set value (in range 5 Hz/s $< df/dt < 15$ Hz/s)
Start time	$f > / f <$ df/dt <80 ms <120 ms
Reset time	<150 ms
Operate time accuracy	$\pm 1.0\%$ of the set value or ± 30 ms

Table 41. Frequency protection (FRPFRQ) main settings

Parameter	Function	Value (Range)	Step
Operation mode	FRPFRQ	1 = Freq< 2 = Freq> 3 = df/dt 4 = Freq< + df/dt 5 = Freq> + df/dt 6 = Freq< OR df/dt 7 = Freq> OR df/dt	-
Start value Freq>	FRPFRQ	0.9000...1.2000 $\times f_n$	0.0001
Start value Freq<	FRPFRQ	0.8000...1.1000 $\times f_n$	0.0001
Start value df/dt	FRPFRQ	-0.2000...0.2000 $\times f_n/s$	0.005
Operate Tm Freq	FRPFRQ	80...200000 ms	10
Operate Tm df/dt	FRPFRQ	120...200000 ms	10

Table 42. Distance protection (DSTPDIS)

Characteristic	Value
Operation accuracy	At the frequency $f = f_n$ Current: $\pm 1.5\%$ of the set value or $\pm 0.002 \times I_n$ Voltage: $\pm 1.5\%$ of the set value or $\pm 0.002 \times U_n$ Impedance: $\pm 2.5\%$ of the set value or $\pm 0.05 \Omega$ Phase angle: $\pm 2^\circ$
Shortest operate time ⁴⁰ SIR ⁴¹ : 0.1...50	45 ms
Transient overreach SIR = 0.1...50	<3%
Reset time	Typically 45 ms
Reset ratio	Typically 0.96/1.04
Operate time accuracy	$\pm 1.0\%$ of the set value or ± 20 ms

40 Measured with High-speed output (HSO)

41 SIR = Source impedance ratio

Table 43. Three-phase underimpedance protection (UZPDIS)

Characteristic	Value
Operation accuracy	Depending on the frequency of the measured current and voltage: $f_n \pm 2$ Hz $\pm 3.0\%$ of the set value or $\pm 0.2 \% Z_b$
Start time ^{42, 43}	Typically 50 ms
Reset time	Typically 40 ms
Reset ratio	Typically 1.04
Retardation time	<40 ms
Operate time accuracy	$\pm 1.0\%$ of the set value or ± 20 ms

Table 44. Three-phase thermal protection for feeders, cables and distribution transformers (T1PTTR)

Characteristic	Value
Operation accuracy	Depending on the frequency of the measured current: $f_n \pm 2$ Hz Current measurement: $\pm 1.5\%$ of the set value or $\pm 0.002 \times I_n$ (at currents in the range of $0.01 \dots 4.00 \times I_n$)
Operate time accuracy ⁴⁴	$\pm 2.0\%$ of the theoretical value or ± 0.50 s

Table 45. Three-phase thermal protection for feeders, cables and distribution transformers (T1PTTR) main settings

Parameter	Function	Value (Range)	Step
Env temperature Set	T1PTTR	-50...100°C	1
Current reference	T1PTTR	$0.05 \dots 4.00 \times I_n$	0.01
Temperature rise	T1PTTR	0.0...200.0°C	0.1
Time constant	T1PTTR	60...60000 s	1
Maximum temperature	T1PTTR	20.0...200.0°C	0.1
Alarm value	T1PTTR	20.0...150.0°C	0.1
Reclose temperature	T1PTTR	20.0...150.0°C	0.1
Current multiplier	T1PTTR	1...5	1
Initial temperature	T1PTTR	-50.0...100.0°C	0.1

Table 46. Circuit breaker failure protection (CCBRBRF)

Characteristic	Value
Operation accuracy	Depending on the frequency of the measured current: $f_n \pm 2$ Hz $\pm 1.5\%$ of the set value or $\pm 0.002 \times I_n$
Operate time accuracy	$\pm 1.0\%$ of the set value or ± 20 ms
Reset time	Typically 40 ms
Retardation time	<20 ms

Table 47. Circuit breaker failure protection (CCBRBRF) main settings

Parameter	Function	Value (Range)	Step
Current value	CCBRBRF	$0.05 \dots 2.00 \times I_n$	0.05
Current value Res	CCBRBRF	$0.05 \dots 2.00 \times I_n$	0.05
CB failure mode	CCBRBRF	1 = Current 2 = Breaker status 3 = Both	-
CB fail trip mode	CCBRBRF	1 = Off 2 = Without check 3 = Current check	-
Retrip time	CCBRBRF	0...60000 ms	10
CB failure delay	CCBRBRF	0...60000 ms	10
CB fault delay	CCBRBRF	0...60000 ms	10

42 $f_n = 50$ Hz, results based on statistical distribution of 1000 measurements

43 Includes the delay of the signal output contact

44 Overload current $> 1.2 \times$ Operate level temperature

SSC600

Product version: 1.1

Table 48. Three-phase inrush detector (INRPHAR)

Characteristic	Value
Operation accuracy	At the frequency $f = f_n$ Current measurement: $\pm 1.5\%$ of the set value or $\pm 0.002 \times I_n$ Ratio I_{2f}/I_{1f} measurement: $\pm 5.0\%$ of the set value
Reset time	+35 ms / -0 ms
Reset ratio	Typically 0.96
Operate time accuracy	+35 ms / -0 ms

Table 49. Three-phase inrush detector (INRPHAR) main settings

Parameter	Function	Value (Range)	Step
Start value	INRPHAR	5...100%	1
Operate delay time	INRPHAR	20...60000 ms	1

Table 50. Switch onto fault (CBPSOF)

Characteristic	Value
Operate time accuracy	$\pm 1.0\%$ of the set value or ± 20 ms

Table 51. Switch onto fault (CBPSOF) main settings

Parameter	Function	Value (Range)	Step
SOTF reset time	CBPSOF	0...60000 ms	1

Table 52. Arc protection (ARCSARC)

Characteristic	Value																				
Operation accuracy	$\pm 3\%$ of the set value or $\pm 0.01 \times I_n$																				
Operate time	<table border="1"> <thead> <tr> <th>Operation mode =</th> <th>Minimum</th> <th>Typical</th> <th>Maximum</th> </tr> </thead> <tbody> <tr> <td>"Light +current"^{45, 46}</td> <td>9 ms⁴⁷</td> <td>12 ms⁴⁷</td> <td>15 ms⁴⁷</td> </tr> <tr> <td></td> <td>4 ms⁴⁸</td> <td>6 ms⁴⁸</td> <td>9 ms⁴⁸</td> </tr> <tr> <td>Operation mode =</td> <td>9 ms⁴⁷</td> <td>10 ms⁴⁷</td> <td>12 ms⁴⁷</td> </tr> <tr> <td>"Light only"⁴⁶</td> <td>4 ms⁴⁸</td> <td>6 ms⁴⁸</td> <td>7 ms⁴⁸</td> </tr> </tbody> </table>	Operation mode =	Minimum	Typical	Maximum	"Light +current" ^{45, 46}	9 ms ⁴⁷	12 ms ⁴⁷	15 ms ⁴⁷		4 ms ⁴⁸	6 ms ⁴⁸	9 ms ⁴⁸	Operation mode =	9 ms ⁴⁷	10 ms ⁴⁷	12 ms ⁴⁷	"Light only" ⁴⁶	4 ms ⁴⁸	6 ms ⁴⁸	7 ms ⁴⁸
Operation mode =	Minimum	Typical	Maximum																		
"Light +current" ^{45, 46}	9 ms ⁴⁷	12 ms ⁴⁷	15 ms ⁴⁷																		
	4 ms ⁴⁸	6 ms ⁴⁸	9 ms ⁴⁸																		
Operation mode =	9 ms ⁴⁷	10 ms ⁴⁷	12 ms ⁴⁷																		
"Light only" ⁴⁶	4 ms ⁴⁸	6 ms ⁴⁸	7 ms ⁴⁸																		
Reset time	<40 ms																				
Reset ratio	Typically 0.96																				

Table 53. Arc protection (ARCSARC) main settings

Parameter	Function	Value (Range)	Step
Phase start value	ARCSARC	0.50...40.00 $\times I_n$	0.01
Ground start value	ARCSARC	0.05...8.00 $\times I_n$	0.01
Operation mode	ARCSARC	1 = Light+current 2 = Light only 3 = BI controlled	-

Table 54. Multipurpose protection (MAPGAPC)

Characteristic	Value
Operation accuracy	$\pm 1.0\%$ of the set value or ± 20 ms

⁴⁵ Phase start value = $1.0 \times I_n$, current before fault = $2.0 \times$ set Phase start value, $f_n = 50$ Hz, fault with nominal frequency, results based on statistical distribution of 200 measurements

⁴⁶ Includes the delay of the heavy-duty output contact

⁴⁷ Normal power output

⁴⁸ High-speed output

SSC600

Product version: 1.1

Table 55. Multipurpose protection (MAPGAPC) main settings

Parameter	Function	Value (Range)	Step
Start value	MAPGAPC	-10000.0...10000.0	0.1
Operate delay time	MAPGAPC	0...200000 ms	100
Operation mode	MAPGAPC	1 = Over 2 = Under	-

Table 56. Fault locator (SCEFRFLO)

Characteristic	Value
Measurement accuracy	At the frequency $f = f_n$ Impedance: $\pm 2.5\%$ or $\pm 0.25 \Omega$ Distance: $\pm 2.5\%$ or ± 0.16 km/0.1 mile XC0F_CALC: $\pm 2.5\%$ or $\pm 50 \Omega$ IFLT_PER_ILD: $\pm 5\%$ or ± 0.05

Table 57. Fault locator (SCEFRFLO) main settings

Parameter	Function	Value (Range)	Step
Z Max phase load	SCEFRFLO	1.0...10000.00 Ω	0.1
Ph leakage Ris	SCEFRFLO	20...1000000 Ω	1
Ph capacitive React	SCEFRFLO	10...1000000 Ω	1
R1 line section A	SCEFRFLO	0.000...1000.000 Ω /pu	0.001
X1 line section A	SCEFRFLO	0.000...1000.000 Ω /pu	0.001
R0 line section A	SCEFRFLO	0.000...1000.000 Ω /pu	0.001
X0 line section A	SCEFRFLO	0.000...1000.000 Ω /pu	0.001
Line Len section A	SCEFRFLO	0.000...1000.000 pu	0.001

Table 58. Multifrequency admittance-based earth-fault protection (MFADPSDE)

Characteristic	Value
Operation accuracy	$\pm 1.0\%$ of the set value or ± 20 ms $\pm 1.5\%$ of the set value or $\pm 0.002 \times U_n$
Start time ⁵⁶	Typically 35 ms
Reset time	Typically 40 ms
Operate time accuracy	$\pm 1.0\%$ of the set value or ± 20 ms

Table 59. Multifrequency admittance-based earth-fault protection (MFADPSDE) main settings

Parameter	Function	Value (Range)	Step
Directional mode	MFADPSDE	2 = Forward 3 = Reverse	-
Voltage start value	MFADPSDE	0.01...1.00 $\times U_n$	0.01
Operate delay time	MFADPSDE	60...1200000	10
Operating quantity	MFADPSDE	1 = Adaptive 2 = Amplitude	-
Min operate current	MFADPSDE	0.005...5.000 $\times I_n$	0.001
Operation mode	MFADPSDE	1 = Intermittent EF 3 = General EF 4 = Alarming EF	-
Peak counter limit	MFADPSDE	2...20	1

Table 60. Negative-sequence overcurrent protection for machines (MNSPTOC)

Characteristic	Value						
Operation accuracy	Depending on the frequency of the measured current: f_n $\pm 1.5\%$ of the set value or $\pm 0.002 \times I_n$						
Start time ^{49, 50}	IFault = $2.0 \times$ set Start value						
	<table border="1"> <thead> <tr> <th>Minimum</th> <th>Typical</th> <th>Maximum</th> </tr> </thead> <tbody> <tr> <td>23 ms</td> <td>25 ms</td> <td>28 ms</td> </tr> </tbody> </table>	Minimum	Typical	Maximum	23 ms	25 ms	28 ms
Minimum	Typical	Maximum					
23 ms	25 ms	28 ms					

49 Negative-sequence current before = 0.0, $f_n = 50$ Hz, results based on statistical distribution of 1000 measurements

50 Includes the delay of the signal output contact

SSC600

Product version: 1.1

Characteristic	Value
Reset time	Typically 40 ms
Reset ratio	Typically 0.96
Retardation time	<35 ms
Operate time accuracy in definite time mode	$\pm 1.0\%$ of the set value or ± 20 ms
Operate time accuracy in inverse time mode	$\pm 5.0\%$ of the theoretical value or ± 20 ms ⁵¹
Suppression of harmonics	DFT: -50 dB at $f = n \times f_n$, where $n = 2, 3, 4, 5, \dots$

Table 61. Negative-sequence overcurrent protection for machines (MNSPTOC) main settings

Parameter	Function	Value (Range)	Step
Start value	MNSPTOC	0.01...0.50 × I _n	0.01
Operating curve type	MNSPTOC	Definite or inverse time Curve type: 5, 15, 17, 18	
Operate delay time	MNSPTOC	100...120000 ms	10
Operation	MNSPTOC	1 = on 5 = off	-
Cooling time	MNSPTOC	5...7200 s	1

Table 62. Loss of load supervision (LOFLPTUC)

Characteristic	Value
Operation accuracy	Depending on the frequency of the measured current: $f_n \pm 2$ Hz $\pm 1.5\%$ of the set value or $\pm 0.002 \times I_n$
Start time	Typically 300 ms
Reset time	Typically 40 ms
Reset ratio	Typically 1.04
Retardation time	<35 ms
Operate time accuracy in definite time mode	$\pm 1.0\%$ of the set value or ± 20 ms

Table 63. Loss of load supervision (LOFLPTUC) main settings

Parameter	Function	Value (Range)	Step
Start value low	LOFLPTUC	0.01...0.50 × I _n	0.01
Start value high	LOFLPTUC	0.01...1.00 × I _n	0.01
Operate delay time	LOFLPTUC	400...600000 ms	10
Operation	LOFLPTUC	1 = on 5 = off	-

Table 64. Motor load jam protection (JAMPTOC)

Characteristic	Value
Operation accuracy	Depending on the frequency of the measured current: $f_n \pm 2$ Hz $\pm 1.5\%$ of the set value or $\pm 0.002 \times I_n$
Start time	Typically 40 ms
Reset time	Typically 0.96
Reset ratio	Typically 1.04
Retardation time	<35 ms
Operate time accuracy in definite time mode	$\pm 1.0\%$ of the set value or ± 20 ms

51 Start value multiples in range of 1.10...5.00

SSC600

Product version: 1.1

Table 65. Motor load jam protection (JAMPTOC) main settings

Parameter	Function	Value (Range)	Step
Operation	JAMPTOC	1 = on 5 = off	-
Start value	JAMPTOC	0.10...10.00 × I _n	0.01
Operate delay time	JAMPTOC	100...120000 ms	10

Table 66. Motor start-up supervision (STTPMSU)

Characteristic	Value
Operation accuracy	Depending on the frequency of the measured current: f _n ±2 Hz
Start time ^{52, 53}	±1.5% of the set value or ±0.002 × I _n
	I _{Fault} = 1.1 × set Start detection A
	Minimum 29 ms
	Typical 30 ms
	Maximum 34 ms
Operate time accuracy	±1.0% of the set value or ±20 ms
Reset ratio	Typically 0.90

Table 67. Motor start-up supervision (STTPMSU) main settings

Parameter	Function	Value (Range)	Step
Motor start-up A	STTPMSU	1.0...10.0 × I _n	
Motor start-up time	STTPMSU	1...80 s	
Lock rotor time	STTPMSU	2...120 s	
Operation	STTPMSU	1 = on 5 = off	
Operation mode	STTPMSU	1 = Ilt 2 = Ilt, CB 3 = Ilt + stall 4 = Ilt + stall, CB	-
Restart inhibit time	STTPMSU	0...250 min	1

Table 68. Phase reversal protection (PREVPTOC)

Characteristic	Value
Operation accuracy	Depending on the frequency of the measured current: f _n ±2 Hz
Start time ^{54, 55}	±1.5% of the set value or ±0.002 × I _n
	I _{Fault} = 2.0 × set Start value
	Minimum 24 ms
	Typical 25 ms
	Maximum 28 ms
Reset time	Typically 40 ms
Reset ratio	Typically 0.96
Retardation time	<35 ms
Operate time accuracy in definite time mode	±1.0% of the set value or ±20 ms
Suppression of harmonics	DFT: -50 dB at f = n × f _n , where n = 2, 3, 4, 5,...

Table 69. Phase reversal protection (PREVPTOC) main settings

Parameter	Function	Value (Range)	Step
Start value	PREVPTOC	0.05...1.00 × I _n	0.01
Operate delay time	PREVPTOC	100...60000 ms	10
Operation	PREVPTOC	1 = on 5 = off	-

52 Current before = 0.0 × I_n, f_n = 50 Hz, overcurrent in one phase, results based on statistical distribution of 1000 measurements

53 Includes the delay of the signal output contact

54 Negative-sequence current before = 0.0, f_n = 50 Hz, results based on statistical distribution of 1000 measurements

55 Includes the delay of the signal output contact

Table 70. Thermal overload protection for motors (MPTR)

Characteristic	Value
Operation accuracy	Depending on the frequency of the measured current: $f_n \pm 2$ Hz Current measurement: $\pm 1.5\%$ of the set value or $\pm 0.002 \times I_n$ (at currents in the range of $0.01 \dots 4.00 \times I_n$)
Operate time accuracy ⁵⁶	$\pm 2.0\%$ of the theoretical value or ± 0.50 s

Table 71. Thermal overload protection for motors (MPTR) main settings

Parameter	Function	Value (Range)	Step
Overload factor	MPTR	1.00...1.20	0.01
Alarm thermal value	MPTR	50.0...100.0%	0.1
Restart thermal Val	MPTR	20.0...80.0%	0.1
Weighting factor p	MPTR	20.0...100.0%	0.1
Time constant normal	MPTR	80...4000 s	1
Time constant start	MPTR	80...4000 s	1
Env temperature mode	MPTR	1 = FLC Only 2 = Use input 3 = Set Amb Temp	-
Env temperature Set	MPTR	-20.0...70.0°C	0.1
Operation	MPTR	1 = on 5 = off	-

Table 72. Three-phase thermal overload protection, two time constants (T2PTTR)

Characteristic	Value
Operation accuracy	Depending on the frequency of the measured current: $f_n \pm 2$ Hz Current measurement: $\pm 1.5\%$ of the set value or $\pm 0.002 \times I_n$ (at currents in the range of $0.01 \dots 4.00 \times I_n$)
Operate time accuracy ⁵⁷	$\pm 2.0\%$ of the theoretical value or ± 0.50 s

Table 73. Three-phase thermal overload protection, two time constants (T2PTTR) main settings

Parameter	Function	Value (Range)	Step
Temperature rise	T2PTTR	0.0...200.0°C	0.1
Max temperature	T2PTTR	0.0...200.0°C	0.1
Operate temperature	T2PTTR	80.0...120.0%	0.1
Short time constant	T2PTTR	6...60000 s	1
Weighting factor p	T2PTTR	0.00...1.00	0.01
Current reference	T2PTTR	0.05...4.00 $\times I_n$	0.01
Operation	T2PTTR	1 = on 5 = off	-

Table 74. Stabilized and instantaneous differential protection for two-winding transformers (TR2PTDF)

Characteristic	Value												
Operation accuracy	Depending on the frequency of the measured current: $f_n \pm 2$ Hz $\pm 3.0\%$ of the set value or $\pm 0.002 \times I_n$												
Start time ^{58, 59}	<table border="1"> <thead> <tr> <th></th> <th>Low stage</th> <th>High stage</th> </tr> </thead> <tbody> <tr> <td>Minimum</td> <td>36 ms</td> <td>21 ms</td> </tr> <tr> <td>Typical</td> <td>41 ms</td> <td>22 ms</td> </tr> <tr> <td>Maximum</td> <td>46 ms</td> <td>24 ms</td> </tr> </tbody> </table>		Low stage	High stage	Minimum	36 ms	21 ms	Typical	41 ms	22 ms	Maximum	46 ms	24 ms
	Low stage	High stage											
Minimum	36 ms	21 ms											
Typical	41 ms	22 ms											
Maximum	46 ms	24 ms											
Reset time	Typically 40 ms												
Reset ratio	Typically 0.96												
Suppression of harmonics	DFT: -50 dB at $f = n \times f_n$, where $n = 2, 3, 4, 5, \dots$												

56 Overload current > 1.2 \times Operate level temperature57 Overload current > 1.2 \times Operate level temperature58 Current before fault = 0.0, $f_n = 50$ Hz, results based on statistical distribution of 1000 measurements59 Includes the delay of the output contact. When differential current = 2 \times set operate value and $f_n = 50$ Hz.

SSC600

Product version: 1.1

Table 75. Stabilized and instantaneous differential protection for two-winding transformers (TR2PTDF) main settings

Parameter	Function	Value (Range)	Step
High operate value	TR2PTDF	500...3000 %Ir	10
Low operate value	TR2PTDF	5...50 %Ir	1
Slope section 2	TR2PTDF	10...50%	1
End section 2	TR2PTDF	100...500 %Ir	1
Restraint mode	TR2PTDF	5 = Waveform 6 = 2.h + waveform 8 = 5.h + waveform 9 = 2.h + 5.h + wav	-
Start value 2.H	TR2PTDF	7...20%	1
Start value 5.H	TR2PTDF	10...50%	1
Operation	TR2PTDF	1 = on 5 = off	-
Winding 1 type	TR2PTDF	1 = Y 2 = YN 3 = D 4 = Z 5 = ZN	-
Winding 2 type	TR2PTDF	1 = Y 2 = YN 3 = D 4 = Z 5 = ZN	-
Zro A elimination	TR2PTDF	1 = Not eliminated 2 = Winding 1 3 = Winding 2 4 = Winding 1 and 2	-

Table 76. Numerically stabilized low-impedance restricted earth-fault protection (LREFPNDF)

Characteristic	Value						
Operation accuracy	Depending on the frequency of the measured current: $f_n \pm 2$ Hz $\pm 2.5\%$ of the set value or $\pm 0.002 \times I_n$						
Start time ^{60, 61}	I _{Fault} = 2.0 × set Operate value <table border="1"> <thead> <tr> <th>Minimum</th> <th>Typical</th> <th>Maximum</th> </tr> </thead> <tbody> <tr> <td>37 ms</td> <td>41 ms</td> <td>45 ms</td> </tr> </tbody> </table>	Minimum	Typical	Maximum	37 ms	41 ms	45 ms
Minimum	Typical	Maximum					
37 ms	41 ms	45 ms					
Reset time	Typically 40 ms						
Reset ratio	Typically 0.96						
Retardation time	<35 ms						
Operate time accuracy in definite time mode	$\pm 1.0\%$ of the set value or ± 20 ms						
Suppression of harmonics	DFT: -50 dB at $f = n \times f_n$, where $n = 2, 3, 4, 5, \dots$						

Table 77. Stabilized restricted earth-fault protection (LREFPNDF) main settings

Parameter	Function	Value (Range)	Step
Operate value	LREFPNDF	5...50 %I _n	1
Minimum operate time	LREFPNDF	40...300000 ms	1
Restraint mode	LREFPNDF	1 = None 2 = Harmonic	-
Start value 2.H	LREFPNDF	10...50%	1
Operation	LREFPNDF	1 = on 5 = off	-

60 Current before fault = 0.0, $f_n = 50$ Hz, results based on statistical distribution of 1000 measurements

61 Includes the delay of the signal output contact

Table 78. Load-shedding and restoration (LSHDPFRQ)

Characteristic		Value
Operation accuracy	f<	±5 mHz
	df/dt	±100 mHz/s (in range df/dt < 5 Hz/s) ± 2.0% of the set value (in range 5 Hz/s < df/dt < 15 Hz/s)
Start time	f<	<80 ms
	df/dt	<120 ms
Reset time		<150 ms
Operate time accuracy		±1.0% of the set value or ±30 ms

Table 79. Load-shedding and restoration (LSHDPFRQ) main settings

Parameter	Function	Value (Range)	Step
Load shed mode	LSHDPFRQ	1 = Freq< 6 = Freq< OR df/dt 8 = Freq< AND df/dt	-
Restore mode	LSHDPFRQ	1 = Disabled 2 = Auto 3 = Manual	-
Start value Freq	LSHDPFRQ	0.800...1.200 × f _n	0.001
Start value df/dt	LSHDPFRQ	-0.2000...0.0050 × f _n /s	0.0001
Operate Tm Freq	LSHDPFRQ	80...200000 ms	10
Operate Tm df/dt	LSHDPFRQ	120...200000 ms	10
Restore start Val	LSHDPFRQ	0.800...1.200 × f _n	0.001
Restore delay time	LSHDPFRQ	80...200000 ms	10

Table 80. Busbar differential protection function (BBPBDF)

Characteristic	Value						
Operation accuracy ⁶²	Depending on the frequency of the measured current: f _n ±2 Hz 3% or 0.005*Ir						
Operate time ^{62, 63, 64, 65}	<table border="1"> <thead> <tr> <th>Minimum</th> <th>Typical</th> <th>Maximum</th> </tr> </thead> <tbody> <tr> <td>16 ms</td> <td>18 ms</td> <td>21 ms</td> </tr> </tbody> </table>	Minimum	Typical	Maximum	16 ms	18 ms	21 ms
Minimum	Typical	Maximum					
16 ms	18 ms	21 ms					
Reset time	Typically 40 ms						
Reset ratio	Typically 0.96						
Retardation time	< 20 ms						
Operate time accuracy	±1.0% of the set value or ±20 ms						
Suppression of harmonics	No suppression						

Table 82. Busbar differential protection function (BBPBDF) main settings

Parameter	Function	Value (Range)	Step
Block value SEF	BBPBDF	50...500 %Ir	1
Reset delay time	BBPBDF	0...60000 ms	1
Start value OCT	BBPBDF	5...50 %Ir	1
Operate value	BBPBDF	5...150 %Ir	1
Operate value CZ	BBPBDF	5...150 %Ir	1
Operate value SEF	BBPBDF	5...150 %Ir	1
Slope section 2	BBPBDF	25...75 %	1
Slope section 2 CZ	BBPBDF	25...75 %	1
Operate delay time	BBPBDF	20...200000 ms	10

62 Sampled value delay 100%. Time synchronization implemented with IEE1588

63 Current before fault 0.0 x I_n. Differential fault current 2 x set Start value

64 Analog measurements connected to from merging unit to SSC600 via IEC 61850-9-2 LE

65 Measured from IO unit static power output. Signalled with IEC 61850-8-1 GOOSE from SSC600.

Table 84. Operation characteristics

Parameter	Value (Range)
Operating curve type	1 = ANSI Ext. inv. 2 = ANSI Very. inv. 3 = ANSI Norm. inv. 4 = ANSI Mod inv. 5 = ANSI Def. Time 6 = L.T.E. inv. 7 = L.T.V. inv. 8 = L.T. inv. 9 = IEC Norm. inv. 10 = IEC Very inv. 11 = IEC inv. 12 = IEC Ext. inv. 13 = IEC S.T. inv. 14 = IEC L.T. inv. 15 = IEC Def. Time 17 = Programmable 18 = Rl type 19 = RD type
Operating curve type (voltage protection)	5 = ANSI Def. Time 15 = IEC Def. Time 17 = Inv. Curve A 18 = Inv. Curve B 19 = Inv. Curve C 20 = Programmable 21 = Inv. Curve A 22 = Inv. Curve B 23 = Programmable

16. Interconnection functions

Table 85. Directional reactive power undervoltage protection (DQPTUV)

Characteristic	Value
Operation accuracy	Depending on the frequency of the measured current and voltage: fn ± 2 Hz Reactive power range PF < 0.71 Power: $\pm 3.0\%$ or $\pm 0.002 \times Q_n$ Voltage: $\pm 1.5\%$ of the set value or $\pm 0.002 \times U_n$
Start time ^{66, 67}	Typically 46 ms
Reset time	< 50 ms
Reset ratio	Typically 0.96
Operate time accuracy	$\pm 1.0\%$ of the set value or ± 20 ms
Suppression of harmonics	DFT: -50 dB at $f = n \times f_n$, where $n = 2, 3, 4, 5, \dots$

Table 86. Directional reactive power undervoltage protection (DQPTUV) main settings

Parameter	Function	Value (Range)	Step
Voltage start value	DQPTUV	0.20...1.20 $\times U_n$	0.01
Operate delay time	DQPTUV	100...300000 ms	10
Min reactive power	DQPTUV	0.01...0.50 $\times S_n$	0.01
Min Ps Seq current	DQPTUV	0.02...0.20 $\times I_n$	0.01
Pwr sector reduction	DQPTUV	0...10°	1

66 Start value = $0.05 \times S_n$, reactive power before fault = $0.8 \times$ Start value, reactive power overshoot 2 times, results based on statistical distribution of 1000 measurements

67 Includes the delay of the signal output contact

Table 87. Low-voltage ride-through protection (LVRTPTUV)

Characteristic	Value
Operation accuracy	Depending on the frequency of the measured voltage: $f_n \pm 2$ Hz $\pm 1.5\%$ of the set value or $\pm 0.002 \times U_n$
Start time ^{68, 69}	Typically 40 ms
Reset time	Based on maximum value of Recovery time setting
Operate time accuracy	$\pm 1.0\%$ of the set value or ± 20 ms
Suppression of harmonics	DFT: -50 dB at $f = n \times f_n$, where $n = 2, 3, 4, 5, \dots$

Table 88. Low-voltage ride-through protection (LVRTPTUV) main settings

Parameter	Function	Value (Range)	Step
Voltage start value	LVRTPTUV	0.05...1.20 × U_n	0.01
Num of start phases	LVRTPTUV	4 = Exactly 1 of 3 5 = Exactly 2 of 3 6 = Exactly 3 of 3"	-
Voltage selection	LVRTPTUV	1 = Highest Ph-to-E 2 = Lowest Ph-to-E 3 = Highest Ph-to-Ph 4 = Lowest Ph-to-Ph 5 = Positive Seq	-
Active coordinates	LVRTPTUV	1...10	1
Voltage level 1	LVRTPTUV	0.00...1.20 ms	0.01
Voltage level 2	LVRTPTUV	0.00...1.20 ms	0.01
Voltage level 3	LVRTPTUV	0.00...1.20 ms	0.01
Voltage level 4	LVRTPTUV	0.00...1.20 ms	0.01
Voltage level 5	LVRTPTUV	0.00...1.20 ms	0.01
Voltage level 6	LVRTPTUV	0.00...1.20 ms	0.01
Voltage level 7	LVRTPTUV	0.00...1.20 ms	0.01
Voltage level 8	LVRTPTUV	0.00...1.20 ms	0.01
Voltage level 9	LVRTPTUV	0.00...1.20 ms	0.01
Voltage level 10	LVRTPTUV	0.00...1.20 ms	0.01
Recovery time 1	LVRTPTUV	0...300000 ms	1
Recovery time 2	LVRTPTUV	0...300000 ms	1
Recovery time 3	LVRTPTUV	0...300000 ms	1
Recovery time 4	LVRTPTUV	0...300000 ms	1
Recovery time 5	LVRTPTUV	0...300000 ms	1
Recovery time 6	LVRTPTUV	0...300000 ms	1
Recovery time 7	LVRTPTUV	0...300000 ms	1
Recovery time 8	LVRTPTUV	0...300000 ms	1
Recovery time 9	LVRTPTUV	0...300000 ms	1
Recovery time 10	LVRTPTUV	0...300000 ms	1

17. Power quality functions

Table 89. Voltage variation (PHQVVR)

Characteristic	Value
Operation accuracy	$\pm 1.5\%$ of the set value or $\pm 0.2\%$ of reference voltage
Reset ratio	Typically 0.96 (Swell), 1.04 (Dip, Interruption)

Table 90. Voltage unbalance (VSQVUB)

Characteristic	Value
Operation accuracy	$\pm 1.5\%$ of the set value or $\pm 0.002 \times U_n$
Reset ratio	Typically 0.96

68 Tested for Number of Start phases = 1 out of 3, results based on statistical distribution of 1000 measurements

69 Includes the delay of the signal output contact

SSC600

Product version: 1.1

18. Control functions

Table 91. Autoreclosing (DARREC)

Characteristic	Value
Operation accuracy	$\pm 1.0\%$ of the set value or ± 20 ms

Table 92. Synchronism and energizing check (SECRSYN)

Characteristic	Value
Operation accuracy	Depending on the frequency of the voltage measured: $f_n \pm 1$ Hz Voltage: $\pm 3.0\%$ of the set value or $\pm 0.01 \times U_n$ Frequency: ± 10 mHz Phase angle: $\pm 3^\circ$
Reset time	<50 ms
Reset ratio	Typically 0.96
Operate time accuracy in definite time mode	$\pm 1.0\%$ of the set value or ± 20 ms

Table 93. Synchronism and energizing check (SECRSYN) main settings

Parameter	Function	Value (Range)	Step
Live dead mode	SECRSYN	-1 = Off 1 = Both Dead 2 = Live L, Dead B 3 = Dead L, Live B 4 = Dead Bus, L Any 5 = Dead L, Bus Any 6 = One Live, Dead 7 = Not Both Live	-
Difference voltage	SECRSYN	$0.01 \dots 0.50 \times U_n$	0.01
Difference frequency	SECRSYN	$0.001 \dots 0.100 \times f_n$	0.001
Difference angle	SECRSYN	$5 \dots 90^\circ$	1
Synchrocheck mode	SECRSYN	1 = Off 2 = Synchronous 3 = Asynchronous	-
Dead line value	SECRSYN	$0.1 \dots 0.8 \times U_n$	0.1
Live line value	SECRSYN	$0.2 \dots 1.0 \times U_n$	0.1
Max energizing V	SECRSYN	$0.50 \dots 1.15 \times U_n$	0.01
Control mode	SECRSYN	1 = Continuous 2 = Command	-
Close pulse	SECRSYN	200...60000 ms	10
Phase shift	SECRSYN	$-180 \dots 180^\circ$	1
Minimum Syn time	SECRSYN	0...60000 ms	10
Maximum Syn time	SECRSYN	100...6000000 ms	10
Energizing time	SECRSYN	100...60000 ms	10
Closing time of CB	SECRSYN	40...250 ms	10

Table 94. Emergency start-up (ESMGAPC)

Characteristic	Value
Operation accuracy	At the frequency $f = f_n$ $\pm 1.5\%$ of the set value or $\pm 0.002 \times U_n$

Table 95. Emergency start-up (ESMGAPC) main settings

Parameter	Function	Value (Range)	Step
Motor standstill A	ESMGAPC	$0.05 \dots 0.20 \times I_n$	0.01
Operation	ESMGAPC	1 = on 5 = off	-

19. Condition monitoring and supervision functions

Table 96. Circuit-breaker condition monitoring (SSCBBR)

Characteristic	Value
Current measuring accuracy	$\pm 1.5\%$ or $\pm 0.002 \times I_n$ (at currents in the range of $0.1 \dots 10 \times I_n$) $\pm 5.0\%$ (at currents in the range of $10 \dots 40 \times I_n$)
Operate time accuracy	$\pm 1.0\%$ of the set value or ± 20 ms
Travelling time measurement	+10 ms / -0 ms

Table 97. Runtime counter for machines and devices (MDSOPT)

Description	Value
Motor runtime measurement accuracy ⁷⁰	$\pm 0.5\%$

20. Measurement functions

Table 98. Three-phase current measurement (CMMXU)

Characteristic	Value
Operation accuracy	Depending on the frequency of the measured current: $f_n \pm 2$ Hz $\pm 0.5\%$ or $\pm 0.002 \times I_n$ (at currents in the range of $0.01 \dots 4.00 \times I_n$)
Suppression of harmonics	DFT: -50 dB at $f = n \times f_n$, where $n = 2, 3, 4, 5, \dots$ RMS: no suppression

Table 99. Sequence current measurement (CSMSQI)

Characteristic	Value
Operation accuracy	Depending on the frequency of the measured current: $f/f_n = \pm 2$ Hz $\pm 1.0\%$ or $\pm 0.002 \times I_n$ at currents in the range of $0.01 \dots 4.00 \times I_n$
Suppression of harmonics	DFT: -50 dB at $f = n \times f_n$, where $n = 2, 3, 4, 5, \dots$ RMS: no suppression

Table 100. Residual current measurement (RESCMMXU)

Characteristic	Value
Operation accuracy	Depending on the frequency of the current measured: $f/f_n = \pm 2$ Hz $\pm 0.5\%$ or $\pm 0.002 \times I_n$ at currents in the range of $0.01 \dots 4.00 \times I_n$
Suppression of harmonics	DFT: -50 dB at $f = n \times f_n$, where $n = 2, 3, 4, 5, \dots$ RMS: No suppression

70 Of the reading, for a stand-alone, without time synchronization

Table 101. Three-phase voltage measurement (VMMXU)

Characteristic	Value
Operation accuracy	Depending on the frequency of the voltage measured: $f_n \pm 2$ Hz At voltages in range $0.01 \dots 1.15 \times U_n$ $\pm 0.5\%$ or $\pm 0.002 \times U_n$
Suppression of harmonics	DFT: -50 dB at $f = n \times f_n$, where $n = 2, 3, 4, 5, \dots$ RMS: No suppression

Table 102. Residual voltage measurement (RESVMMXU)

Characteristic	Value
Operation accuracy	Depending on the frequency of the measured current: $f/f_n = \pm 2$ Hz $\pm 0.5\%$ or $\pm 0.002 \times U_n$
Suppression of harmonics	DFT: -50 dB at $f = n \times f_n$, where $n = 2, 3, 4, 5, \dots$ RMS: No suppression

Table 103. Sequence voltage measurement (VSMSQI)

Characteristic	Value
Operation accuracy	Depending on the frequency of the voltage measured: $f_n \pm 2$ Hz At voltages in range $0.01 \dots 1.15 \times U_n$ $\pm 1.0\%$ or $\pm 0.002 \times U_n$
Suppression of harmonics	DFT: -50 dB at $f = n \times f_n$, where $n = 2, 3, 4, 5, \dots$

Table 104. Three-phase power and energy measurement (PEMMXU)

Characteristic	Value
Operation accuracy	At all three currents in range $0.10 \dots 1.20 \times I_n$ At all three voltages in range $0.50 \dots 1.15 \times U_n$ At the frequency $f_n \pm 1$ Hz $\pm 1.5\%$ for apparent power S $\pm 1.5\%$ for active power P and active energy ⁷¹ $\pm 1.5\%$ for reactive power Q and reactive energy ⁷² ± 0.015 for power factor
Suppression of harmonics	DFT: -50 dB at $f = n \times f_n$, where $n = 2, 3, 4, 5, \dots$

Table 105. Frequency measurement (FMMXU)

Characteristic	Value
Operation accuracy	± 5 mHz (in measurement range 35...75 Hz)

21. Other functions

Table 106. Pulse timer (PTGAPC)

Characteristic	Value
Operation accuracy	$\pm 1.0\%$ of the set value or ± 20 ms

Table 107. Time delay off (8 pcs) (TOFGAPC)

Characteristic	Value
Operation accuracy	$\pm 1.0\%$ of the set value or ± 20 ms

Table 108. Time delay on (8 pcs) (TONGAPC)

Characteristic	Value
Operation accuracy	$\pm 1.0\%$ of the set value or ± 20 ms

⁷¹ $|PF| > 0.5$ which equals $|\cos \varphi| > 0.5$

⁷² $|PF| < 0.86$ which equals $|\sin \varphi| > 0.5$

22. WHMI

The WHMI allows secure access to the device via a Web browser. When the Secure Communication parameter in the device is activated, the Web server is forced to take a secured (HTTPS) connection to WHMI using TLS encryption. The Web HMI is verified with Internet Explorer 11, Firefox and Google Chrome.

WHMI offers several functions.

- Programmable virtual LEDs and event lists
- System supervision
- Parameter settings
- Measurement display
- Disturbance records
- Fault records
- Load profile record
- Phasor diagram
- Single line diagram
- Importing/Exporting parameters
- Report summary

The WHMI can be accessed locally and remotely.

- Locally by connecting the laptop to the device via the local WHMI port.
- Remotely over LAN/ WAN.

WHMI display offer front-panel user interface functionality with menu navigation and menu views. In addition, WHMI includes a user-configurable single line diagram (SLD) with position indication for the associated primary equipment. The device displays the related measuring values, apart from the default single line diagram. The default SLD can be modified according to user requirements by using the Graphical Display Editor in PCM600.

23. Selection and ordering data

Use [ABB Library](#) to access the selection and ordering information and to generate the order number.

[Product Selection Tool](#) (PST), a Next-Generation Order Number Tool, supports order code creation for ABB Distribution Automation IEC products with emphasis on but not exclusively for the Relion product family. PST is an easy to use, online tool always containing the latest product information. The complete order code can be created with detailed specification and the result can be printed and mailed. Registration is required.

24. Tools

The protection device is delivered as a preconfigured unit. The default parameter setting values can be changed from the frontpanel user interface (local HMI), the Web browser based user interface (Web HMI) or Protection and Control IED Manager PCM600 in combination with the IED-specific connectivity package.

SSC600

Product version: 1.1

PCM600 offers extensive IED configuration functions. For example, depending on the protection IED, the IED signals, application, graphical display and single-line diagram, and IEC 61850 communication, including horizontal GOOSE communication, can be modified with PCM600.

When the Web HMI is used, the protection device can be accessed either locally or remotely using a Web browser (Internet Explorer). The Web HMI functionality can be limited to read-only access. Local control from Web HMI is possible only when the device is accessed from the local Web HMI Ethernet port.

Table 109. Tools

Description	Version
PCM600	2.9 or later
Web browser	Google Chrome, latest version Mozilla Firefox, latest version Microsoft Edge, latest version
SSC600 Connectivity Package	1.1 or later

Table 110. Supported functions

Function	Web HMI	PCM600
Device parameter setting	•	•
Saving of device parameter settings in the device	•	•
Signal monitoring	•	•
Disturbance recorder handling	•	•
Alarm LED viewing	•	•
Access control management	•	•
device signal configuration (Signal Matrix)	-	•
Saving of device parameter settings in the tool	-	•
Disturbance record analysis	-	•
XRIO parameter export/import	•	•
Graphical display configuration	-	•
Application configuration	-	•
IEC 61850 communication configuration, GOOSE (communication configuration)	-	•
Phasor diagram viewing	•	-
Event viewing	•	•
Saving of event data on the user's PC	•	•
Online monitoring	-	•

• = Supported

SSC600

Product version: 1.1

25. Cyber security

The device supports role based user authentication and authorization. It can store 2048 audit trail events to a nonvolatile memory. The non-volatile memory is based on a memory type which does not need battery backup or regular component exchange to maintain the memory storage. FTP and Web HMI use TLS encryption with a minimum of 128 bit key length protecting the data in transit. In this case the used communication protocols are FTPS and HTTPS. All rear communication ports and optional protocol services can be deactivated according to the required system setup.

26. References

The www.abb.com/mediumvoltage portal provides information on the entire range of distribution automation products and services. The latest relevant information on the related protection and control IEDs and merging units can be found on the respective product pages. Product pages include a complete set of product documentation.

27. Functions, codes and symbols

Table 111. Protection

Function	IEC 61850	IEC 60617	ANSI
Three-phase non-directional overcurrent protection, low stage	PHLPTOC1	3I> (1)	51P-1 (1)
Three-phase non-directional overcurrent protection, high stage	PHHPTOC1	3I>> (1)	51P-2 (1)
Three-phase non-directional overcurrent protection, instantaneous stage	PHIPTOC1	3I>>> (1)	50P (1)
Three-phase directional overcurrent protection, low stage	DPHLPDOC1	3I> -> (1)	67P/51P-1 (1)
Three-phase directional overcurrent protection, high stage	DPHHPDOC1	3I>> -> (1)	67P/51P-2 (1)
Non-directional earthfault protection, low stage	EFLPTOC1	I0> (1)	51G/51N-1 (1)
Non-directional earthfault protection, high stage	EFHPTOC1	I0>> (1)	51G/51N-2 (1)
Non-directional earthfault protection, instantaneous stage	EFIPTOC1	I0>>> (1)	50G/50N (1)
Directional earth-fault protection, low stage	DEFLPDEF1	I0> -> (1)	67G/N-1 51G/N-1 (1)
Directional earth-fault protection, high stage	DEFHPDEF1	I0>> -> (1)	67G/N-1 51G/N-2 (1)
Admittance-based earth-fault protection	EFPADM1	Y0> -> (1)	21YN (1)
Wattmetric-based earth-fault protection	WPWDE1	P0> -> (1)	32N (1)
Transient/intermittent earth-fault protection	INTRPTEF1	I0> -> IEF (1)	67NTEF/NIEF (1)
Non-directional (crosscountry) earth-fault protection, using calculated I0	EFHPTOC1	I0>> (1)	51G/51N-2 (1)
Negative-sequence overcurrent protection	NSPTOC1	I2> (1)	46M (1)
Phase discontinuity protection	PDNSPTOC1	I2/I1> (1)	46PD (1)
Residual overvoltage protection	ROVPTOV1	U0> (1)	59G/59N (1)
Three-phase undervoltage protection	PHPTUV1	3U< (1)	27 (1)
Three-phase overvoltage protection	PHPTOV1	3U> (1)	59 (1)
Positive-sequence undervoltage protection	PSPTUV1	U1< (1)	27PS (1)
Negative-sequence overvoltage protection	NSPTOV1	U2> (1)	59NS (1)
Frequency protection	FRPFRQ1	f>/f<, df/dt (1)	81 (1)
Distance protection	DSTPDIS	Z< (1)	21P, 21N (1)
Three-phase underimpedance protection	UZPDIS	Z<G (1)	21G (1)
Three-phase thermal protection for feeders, cables and distribution transformers	T1PTTR1	3Ith>F (1)	49F (1)

SSC600

Product version: 1.1

Function	IEC 61850	IEC 60617	ANSI
Circuit breaker failure protection	CCBRBRF1	3l>/lo>BF (1)	50BF (1)
Three-phase inrush detector	INRPBAR1	3I2f> (1)	68HB (1)
Switch onto fault	CBPSOF1	SOTF (1)	SOTF (1)
Master trip	TRPPTRC1	Master Trip (1)	94/86 (1)
Arc protection	ARCSARC1	ARC (1)	AFD (1)
Multipurpose protection	MAPGAPC1	MAP (1)	MAP (1)
Fault locator	SCEFRFLO1	FLOC (1)	FLOC (1)
Reverse power/directional overpower protection	DOPDPDR1	P>/Q> (1)	32R/32O (1)
Multifrequency admittance-based earth-fault protection	MFADPSDE1	lo> ->Y (1)	67NYH (1)
Negative-sequence overcurrent protection for machines	MNSPTOC1	I2>M (1)	46M (1)
Loss of load supervision	LOFLPTUC1	3I< (1)	37 (1)
Motor load jam protection	JAMPPTOC1	Ist> (1)	50TDJAM (1)
Motor start-up supervision	STTPMSU1	Is2t n< (1)	49,66,48,50TDLR (1)
Phase reversal protection	PREVPTOC1	I2>> (1)	46R (1)
Thermal overload protection for motors	MPTTR1	3Ith>M (1)	49T/G/C (1)
Three-phase thermal overload protection, two time constants	T2PTTR1	3Ith>T/G/C (1)	49T/G/C (1)
Stabilized and instantaneous differential protection for two-winding transformers	TR2PTDF1	3dl>T (1)	87T (1)
Numerically stabilized low-impedance restricted earthfault protection	LREFPND1	dIoLo> (1)	87NLI (1)
Busbar differential protection	BBPBDF	3Id/I	87BL
Busbar zone selection	ZNRCRC	ZNRSRC	ZNRSRC
Load-shedding and restoration	LSHDPPFRQ	UFLS/R	81LSH
Tap changer control with voltage regulator (Single-bay Volt-reg)	OLATCC		

Table 112. Interconnection functions

Function	IEC 61850	IEC 60617	IEC-ANSI
Directional reactive power undervoltage protection	DQPTUV1	Q> ->,3U< (1)	32Q,27 (1)
Low-voltage ride through protection	LVRTPTUV1	U<RT (1)	27RT (1)

Table 113. Power quality

Function	IEC 61850	IEC 60617	IEC-ANSI
Current total demand distortion	CMHAI1	PQM3I (1)	PQM3I (1)
Voltage total harmonic distortion	VMHAI1	PQM3U (1)	PQM3V (1)
Voltage variation	PHQVVR1	PQMU (1)	PQMV (1)
Voltage unbalance	VSQVUB1	PQUUB (1)	PQVUB (1)

Table 114. Control

Function	IEC 61850	IEC 60617	IEC-ANSI
Circuit-breaker control	CBXCBR1	I <-> O CB (1)	I <-> O CB (1)
Disconnecter control	DCXSWI1	I <-> O DCC (1)	I <-> O DCC (1)
Earthing switch control	ESXSWI1	I <-> O ESC (1)	I <-> O ESC (1)
Disconnecter position indication	DCXSWI1	I <-> O DC (1)	I <-> O DC (1)
Earthing switch indication	ESSXSWI1	I <-> O ES (1)	I <-> O ES (1)
Autoreclosing	DARREC1	O -> I (1)	79 (1)
Synchronism and energizing check	SECRSYN1	SYNC (1)	25 (1)
Tap changer position indication	TPOSYLTC1	TPOSM (1)	84M (1)
Emergency start-up	ESMGAPC	ESTART	EST,62

SSC600

Product version: 1.1

Function	IEC 61850	IEC 60617	IEC-ANSI
Parameter setting groups	PROTECTION	PROTECTION	PROTECTION

Table 115. Condition monitoring and supervision

Function	IEC 61850	IEC 60617	IEC-ANSI
Circuit-breaker condition monitoring	SSCBR1	CBCM (1)	CBCM (1)
Runtime counter for machines and devices	MDSOPT1	OPTS (1)	OPTM (1)

Table 116. Measurement

Function	IEC 61850	IEC 60617	IEC-ANSI
Disturbance recorder	RDRE1	DR (1)	DFR (1)
Fault record	FLTRFRC1	FAULTREC (1)	FAULTREC (1)
Three-phase current measurement	CMMXU1	3I (1)	3I (1)
Sequence current measurement	CSMSQ1	I1, I2, I0 (1)	I1, I2, I0 (1)
Residual current measurement	RESCMMXU1	Io (1)	In (1)
Three-phase voltage measurement	VMMXU1	3U (1)	3V (1)
Residual voltage measurement	RESVMMXU1	Uo (1)	Vn (1)
Sequence voltage measurement	VSMSQ1	U1, U2, U0 (1)	V1, V2, V0 (1)
Three-phase power and energy measurement	PEMMXU1	P, E (1)	P, E (1)
Frequency measurement	FMMXU1	f (1)	f (1)
IEC 61850-9-2 LE sampled value receiving (voltage sharing)	SMVRECEIVE	SMVRECEIVE	SMVRECEIVE

Table 117. Other

Function	IEC 61850	IEC 60617	IEC-ANSI
Voltage switch	VMSWI	VSWI	VSWI
Current sum	CMSUM	CSUM	CSUM
Current switch	CMSWI	CMSWI	CMSWI
Minimum pulse timer	TPGAPC1	TP (1)	TP (1)
Minimum pulse timer (second resolution)	TPSGAPC1	TPS (1)	TPS (1)
Minimum pulse timer (minute resolution)	TPMGAPC1	TPM (1)	TPM (1)
Pulse timer (8 pcs)	PTGAPC1	PT (1)	PT (1)
Time delay off (8 pcs)	TOFGAPC1	TOF (1)	TOF (1)
Time delay on (8 pcs)	TONGAPC1	TON (1)	TON (1)
Set-reset (8 pcs)	SRGAPC1	SR (1)	SR (1)
Move (8 pcs)	MVGAPC1	MV (1)	MV (1)
Generic control point (16 pcs)	SPCGAPC1	SPC (1)	SPC (1)
Analog value scaling	SCA4GAPC1	SCA4 (1)	SCA4 (1)
Integer value move	MVI4GAPC1	MVI4 (1)	MVI4 (1)
Time master supervision	GNRLLTMS	GNRLLTMS	GNRLLTMS
IEC 61850-1 MMS	MMSLPRT	MMSLPRT	MMSLPRT
IEC 61850-1 GOOSE	GSELPRT	GSELPRT	GSELPRT
Local/Remote control	CONTROL	CONTROL	CONTROL

SSC600

Product version: 1.1

28. Order form

Table 118. Order code example

Order code digits																
1	2	3	4	5	6	7	8	9	10	11	12	13	14	15	16	17
S	B	A	C	A	N	A	N	A	A	A	1	A	N	N	1	2G

Table 119. Order code

Name	Allowed Character	Code	Description	Order code digits					
				1	2	3	4	5	6
Basic Product	A-9 or A-Z	S	SSC600 base unit with 8 x RJ45 LAN ports, 2 x SSD @ 32GB for storage	S					
Standard	A-9 or A-Z	B	IEC		B				
Main Application Package	A-9 or A-Z	A	Multi-Feeder Protection and Control: Basic protection, control, measurement, monitoring and logic functions			A			
Cable/Line Application Package	A-9 or A-Z	A	Cable/line Application Package for 5 feeders				C		
		B	Cable/line Application Package for 10 feeders						
		C	Cable/line Application Package for 15 feeders						
		D	Cable/line Application Package for 20 feeders						
		N	None						
Advanced Cable/Line Application Package	A-9 or A-Z	A	Advanced cable/line Application Package for 5 feeders					A	
		B	Advanced cable/line Application Package for 10 feeders						
		C	Advanced cable/line Application Package for 15 feeders						
		D	Advanced cable/line Application Package for 20 feeders						
		N	None						
Spare	A-9 or A-Z	N	Not used						N

Table 120. Order code

Name	Allowed Character	Code	Description	Order code digits					
				7	8	9	10	11	12
Transformer Application Package	A-9 or A-Z	A	Transformer Application Package for 2 feeders	A					
		B	Transformer Application Package for 4 feeders						
		N	None						
Motor Application Package	A-9 or A-Z	A	Motor Application Package for 5 feeders		N				
		B	Motor Application Package for 10 feeders						
		C	Motor Application Package for 15 feeders						
		D	Motor Application Package for 20 feeders						
		N	None						
IEC 61850-9-2LE Process Bus Connectivity	A-9 or A-Z	A	Connectivity with up to 10 merging units/relays			A			
		B	Connectivity with up to 15 merging units/relays						
		C	Connectivity with up to 20 merging units/relays						
Communication	A-9 or A-Z	A	No additional communication cards				A		
		B	Ethernet 1000Base SX (2 x LC with PRP)						
Communication protocol	A-9 or A-Z	A	IEC 61850					A	
Language	1-9	1	English						1

Table 121. Order code

Name	Allowed Character	Code	Description	Order code digits				
				13	14	15	16	17
User interface	A-9 or A-Z	A	Default WebHMI	A				
Special Bay-level Application Package	A-9	A	Power quality		N			
		B	Voltage regulation					
		C	Distance protection					
		D	Power quality + Voltage regulation					
		E	Power quality + Distance protection					
		F	Voltage regulation + Distance protection					
		G	Power quality + Voltage regulation + Distance protection					
Special Multi-bay Application Package	A-9 or A-Z	A	Arc protection			N		
		B	Frequency load-shedding					
		C	Arc protection + Frequency load-shedding					
		D	Busbar differential protection					
		E	Arc protection + Busbar differential protection					
		F	Frequency load-shedding + Busbar differential protection					
		G	Arc protection + Frequency load-shedding + Busbar differential protection					
Power supply	1-9	1	Redundant power supply: 2 x HV power supply (100-250V AC/DC)					1
		2	Redundant power supply: 2 x LV power supply (36-72VDC)					
Product version	1-9 A-9	2G	1.0					2G

SSC600

Product version: 1.1

29. Application Packages

29.1 Base App

Base application package is always included in SSC600 and contains following functions instances. Amount of circuit breaker control functions and SMV receiver functions depends on the Digit 9 selection.

Table 122. Protection functions

Function Name	IEC 61850 Name	Number of Instances
Three-phase non-directional overcurrent protection, low stage	PHLPTOC	40
Three-phase non-directional overcurrent protection, high stage	PHHPTOC	20
Three-phase non-directional overcurrent protection, instantaneous stage	PHIPTOC	20
Non-directional earth-fault protection, low stage	EFLPTOC	40
Non-directional earth-fault protection, high stage	EFHPTOC	20
Non-directional earth-fault protection, instantaneous stage	EFIPTOC	20
Negative-sequence overcurrent protection	NSPTOC	40
Residual overvoltage protection	ROVPTOV	8
Three-phase undervoltage protection for 10 feeders (across 4 bus sections)	PHPTUV	40
Three-phase overvoltage protection for 10 feeders (across 4 bus sections)	PHPTOV	8
Positive-sequence undervoltage protection for 10 feeders (across 4 bus sections)	PSPTUV	40
Negative-sequence overvoltage protection for 10 feeders (across 4 bus sections)	NSPTOV	8
Frequency protection for 4 bus sections	FRPFRQ	16
High impedance based restricted earth-fault protection	HREFPDIF	20
Circuit breaker failure protection	CCBRBRF	20
Three-phase inrush detector	INRPHAR	20
Switch onto fault	CBPSOF	20
Master trip	TRPPTRC	40
Multipurpose analog protection	MAPGAPC	40
Busbar differential protection	BBPBDF	1
Busbar zone selection	ZNRCRC	20

Table 123. Control

Function Name	IEC 61850 Name	Number of Instances
Circuit-breaker control	CBXCBR	5...20
Disconnecter control	DCXSWI	40
Earthing switch control	ESXSWI	20
Disconnecter position indication	DCSXSWI	60
Earthing switch position indication	ESSXSWI	40

Table 124. Condition Monitoring

Function Name	IEC 61850 Name	Number of Instances
Circuit-breaker condition monitoring	SSCBR	20

Table 125. Measurement

Function Name	IEC 61850 Name	Number of Instances
Three-phase current measurement	CMMXU	20
Sequence current measurement	CSMSQI	20
Residual current measurement	RESCMMXU	20
Three-phase voltage measurement	VMMXU	4
Residual voltage measurement	RESVMMXU	4
Sequence voltage measurement	VSMSQI	4
Three-phase power and energy measurement	PEMMXU	20
Load profile	LDPRLRC	20
Frequency measurement for 4 bus sections	FMMXU	4

Table 126. Traditional LED indication

Function Name	IEC 61850 Name	Number of Instances
LED indication control	LEDPTRC	1

Table 127. Logging functions

Function Name	IEC 61850 Name	Number of Instances
Disturbance recorder	RDRE	1
Fault recorder	FLTRFRC	1

Table 128. Other functionality

Function Name	IEC 61850 Name	Number of Instances
OR-gate with two inputs	OR2	800
OR-gate with six inputs	OR6	400
OR-gate with twenty inputs	OR20	200
AND-gate with two inputs	AND2	800
AND-gate with six inputs	AND6	400
AND-gate with twenty inputs	AND20	200
XOR-gate with two inputs	XOR2	200
Negation-gate	NOT	400
Selects the highest analogue value out of the three inputs	MAX3	200
Selects the lowest analogue value out of the three inputs	MIN3	200
Gives a pulse out of the detected rising edge in the input	R_TRIG	100
Gives a pulse out of the detected falling edge in the input	F_TRIG	100
SWITCHR-function	SWITCHR	600
SR flip-flop, non volatile	SR	200
Minimum pulse timer, two channel	TPGAPC	80
Minimum pulse timer seconds resolution, two channel	TPSGAPC	20
Minimum pulse timer minutes resolution, two channel	TPMGAPC	20
Pulse timer, eight channel	PTGAPC	40
Time delay off, eight channel	TOFGAPC	80
Time delay on, eight channel	TONGAPC	80
SR flip-flop, eight channel with volatile memory	SRGAPC	80
Move, eight channel	MVGAPC	40

SSC600

Product version: 1.1

Function Name	IEC 61850 Name	Number of Instances
Create events based on Integer values, four channel	MV14GAPC	20
Analogue value scaling and event creation, four channel	SCA4GAPC	80
Function related to SMV stream receiver	SMVRECEIVE	5...20
Received GOOSE Binary information	GOOSERCV_BIN	400
Received GOOSE Double Binary information	GOOSERCV_DP	200
Received GOOSE Measured Value information	GOOSERCV_MV	200
Received GOOSE 8bit Integer Value information	GOOSERCV_INT8	200
Received GOOSE 32bit Integer Value information	GOOSERCV_INT32	200
Received GOOSE Interlocking information	GOOSERCV_INTL	200
Received GOOSE Measured Value (phasor) information	GOOSERCV_CMV	80
Received GOOSE Enumerator Value information	GOOSERCV_ENUM	200
Current sum	CMSUM	20
Voltage switch	VMSWI	20
Current switch	CMSWI	20

29.2 Feeder Application Package

Feeder Application Package can be selected with order code Digit 4, and it can be selected for 5, 10, 15 or 20 feeders. The size of the package impacts the number of available function instances. The content of the package is described in the table below.

Table 129. Protection

Function Name	IEC 61850 Name	Number of Instances			
		5 Feeders	10 Feeders	15 Feeders	20 Feeders
Three-phase directional overcurrent protection, low stage	DPHLPDOC	15	30	45	60
Three-phase directional overcurrent protection, high stage	DPHPDOC	15	30	45	60
Directional earth-fault protection, low stage	DEFLPDEF	15	30	45	60
Directional earth-fault protection, high stage	DEFHPDEF	5	10	15	20
Three-phase directional overpower (reverse power) protection	DOPDPDR	5	10	15	20
Phase discontinuity protection	PDNSPTOC	10	20	30	40
Three-phase thermal protection for feeders, cables and distribution transformers	T1PTTR	10	20	30	40

29.3 Advanced Feeder Application Package

Advanced Feeder Application Package can be selected with order code Digit 5, and it can be selected for 5,10,15 or 20 feeders.

The size of the package impacts the number of available function instances. The content of the package is described in the table below.

Table 130. Protection

Function Name	IEC 61850 Name	Number of Instances			
		5 Feeders	10 Feeders	15 Feeders	20 Feeders
Admittance based earth-fault protection	EFPADM	15	30	45	60
Multi-frequency admittance-based earth-fault protection	MFADPSDE	15	30	45	60
Wattmetric based earth-fault protection	WPWDE	15	30	45	60
Transient / intermittent earth-fault protection	INTRPTEF	5	10	15	20
Fault locator	SCEFRFLO	5	10	15	20
Directional reactive power under voltage protection	DQPTUV	5	10	15	20
Low voltage ride through protection	LVRTPTUV	15	30	45	60
Autoreclosing	DARREC				
Synchronism and energizing check	SECRSYN				

29.4 Transformer Application Package

Transformer Application Package can be selected with order code Digit 7, and it can be selected for 2 or 4 feeders. The size of the package impacts the number of available function instances. The content of the package is described in the table below.

Table 131. Protection

Function Name	IEC 61850 Name	Number of Instances	
		2 Feeders	4 Feeders
Three-phase thermal overload protection for power transformers, two time constants	T2PTTR	2	4
Stabilized and instantaneous differential protection for 2-winding transformers	TR2PTDF	2	4
Numerical stabilized low impedance restricted earth-fault protection	LREFPNDF	2	4

Table 132. Control

Function Name	IEC 61850 Name	Number of Instances	
		2 Feeders	4 Feeders
Tap changer position indication	TPOSYLTC	2	4

SSC600

Product version: 1.1

29.5 Motor Application Package

Motor Application Package can be selected with order code Digit 8, and it can be selected for 5, 10, 15 or 20 feeders. The size of the package impacts the number of available function instances. The content of the package is described in the table below.

Table 133. Protection

Function Name	IEC 61850 Name	Number of Instances			
		5 Feeders	10 Feeders	15 Feeders	20 Feeders
Negative-sequence overcurrent protection for motors	MNSPTOC	10	20	30	40
Loss of load supervision	LOFLPTUC	5	10	15	20
Motor load jam protection	JAMPTOC	5	10	15	20
Motor start-up supervision	STTPMSU	5	10	15	20
Phase reversal protection	PREVPTOC	5	10	15	20
Thermal overload protection for motors	MPTR	5	10	15	20

29.6 Special Application Package

Special optional applications can be selected with order code Digits 14 and 15. The content of the package is described in the table below.

Table 134. Special AppPack

Function Name	IEC 61850 Name	Number of Instances
Arc flash protection (Multi-bay)	ARCSARC	60
Load shedding and restoration across 4 bus sections (Multi-bay)	LSHDPFRQ	20
Tap changer control with voltage regulator (Single-bay Volt-reg)	OLATCC	-
Petersen coil passive controller (Single-bay PCC)	PASANCR	1
Current total demand and harmonic distortion (TDD and THD) (Single-bay PQI)	CH00MHAI	20
Voltage total harmonic distortion (THD) (Single-bay PQU)	VH00MHAI	4
Voltage variation (Single-bay PQU)	PHQVVR	4
Voltage unbalance (Single-bay PQU)	VSQVUB	4

ABB Distribution Solutions
Distribution Automation

P.O. Box 699

FI-65101 VAASA, Finland

Phone +358 10 22 11

Fax +358 10 22 41094

www.abb.com/mediumvoltage